

# Round Cube

## Exterior construction guide

Round Cube (DOUBLE 2.4 and 2.6)

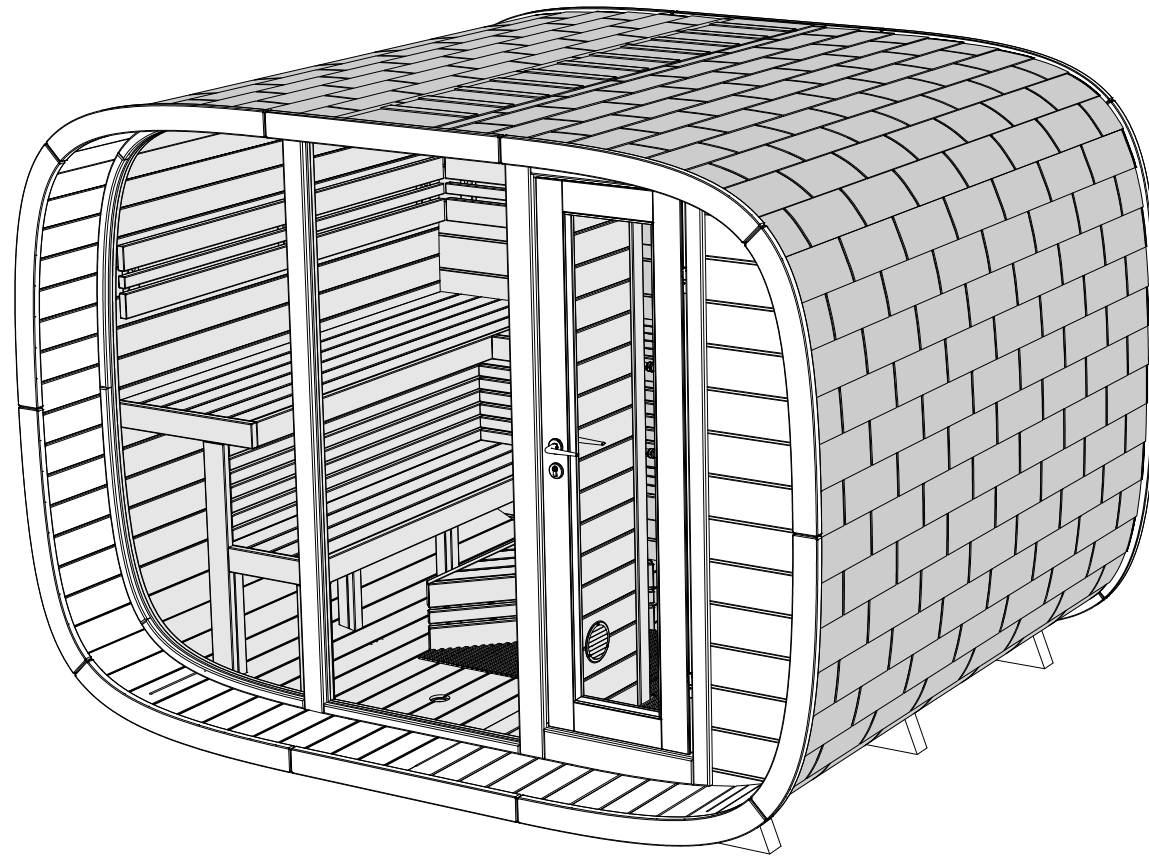

*Read the manual and check the parts for completeness before assembly!*

## USER MANUAL OF THE SAUNA

1. It is recommended to install the sauna above ground level to prevent the legs of the sauna from coming into direct contact with the ground. Install a water-resistant material, such as bitumen strips, between the legs of the sauna and the base.
2. Make sure that the surface on which you install the sauna is levelled and stable both before and after installing the sauna. Otherwise, the doors of the sauna may not open and close properly.
3. If the top part of the chimney has not been installed upon delivery of the sauna, it should be placed into the chimney pipe from the roof of the sauna.
4. During the first heating of the sauna, it must be constantly supervised and the doors should be kept open, as the stove emits a specific smell when first heated. Read more from the user manual of the sauna stove.
5. The maximum permitted temperature of the steam room is **+90 °C**. If heated to a higher temperature, the sauna may be overheated.
6. After each use of the sauna, it is recommended to keep the stove warm, the doors open, and the footrests up for a while to allow the sauna to dry from the inside. If necessary, the water on the floor should be directed to the drain with a floor scraper to avoid damage caused by excess humidity.
7. **When the weather is humid and if the wood has expanded, the metal hoops around the sauna should be loosened to avoid breaking the clamps and jamming the doors.** The hoops can be adjusted from the nut of clamp M12 located on the side of the sauna. To alleviate excess tension on the clamp and the hoop itself, loosen nut M12 (wrench no. 19) until the hoop can be shifted left and right. Then, re-tighten the nut until the hoop is under slight pressure and pressed fully against the wood so that it cannot be pulled away from the walls of the sauna. **When the weather is less humid and the wood has dried, the metal hoops around the sauna should be tightened from nut M12.** Tighten the nut so the hoop is under slight pressure. The hoop must be pressed fully against the wood so that it cannot be pulled away from the walls of the sauna. Saunasell OÜ is not liable for damage caused to the sauna due to a broken hoop clamp.
8. If the door is shifted out of place when the hoops are tightened, lift the exterior door off the hinges and regulate the hinges. If this is not a sufficient solution, remove the trims of the door and unscrew the screws of the doorframe beneath them. This will relieve the pressure on the door. If necessary, the opening of the door may be made wider, after which the screws should be re-tightened and the trims and door reinstalled.
9. The interior door should be regulated from the stopper and, if necessary, the hinges. If this is not a sufficient solution, remove the trims of the door and unscrew the screws of the doorframe beneath them. This will relieve the pressure on the door.
10. Locking the sauna door from the inside is prohibited.
11. In order to avoid damage caused by the weight of snow, any snow should be removed from the roof of the sauna. Keep in mind that the roof covering should not be damaged during snow removal.
12. If your sauna has lighting, install a 3G 2,5 mm<sup>2</sup> outdoor power cable and connect it in juniper box provided with the sauna (L1 – brown , N – blue , GR – green-yellow). The power cable of the sauna must be connected to a residual-current circuit breaker! Consult an electrician if necessary.

## Maintenance of the sauna

1. **The interior surfaces of the sauna, the window frames of the steam and washing room, and the frames of interior doors must be treated with a special substance before initial use to protect them from humidity and dirt and extend the useful life of the sauna.** Later, this should be done once or twice a year. TEKNOS Satu Saunasuoja or Tikkurila Supi Saunasuoja may be used for this.
2. **Before initial use of the sauna, the benches and footrests must be treated with a protective oil to extend their useful life.** Later, this should be done once or twice a year. TEKNOS Satu Laudesuoja or Tikkurila Supi Laudesuoja may be used for this.
3. **Before initial use of the sauna and once a year after that, the door, doorframe, threshold, and window frame of the anteroom as well as the floors of the washing room and anteroom should be treated with the lacquer Teknos Helo Aqua 40.**
4. **The exterior surfaces of the sauna are given the first protective coating during production. The second coating should be applied approximately two months after purchasing the sauna to extend its useful life and maintain its appearance.** Use Remmers Aidol HK-Lasur for this. The substance is available for purchase at Saunasell OÜ or from the website <https://trendwood.ee/tooted/viimistlus/remmers/>
5. Saunasell OÜ is not liable for damage caused to the sauna due to insufficient maintenance or no maintenance at all.

## WARRANTY

- The products have a 24-month warranty covering material and production defects, taking effect from the delivery of the sauna to the client.
- The warranty is valid if the user has reviewed the user manuals and abides by them.
- The warranty is void if the sauna has not been assembled by Saunasell OÜ.
- Please note! The warranty period differs for products on trailers and products intended for commercial use.
- The warranty does not cover defects characteristic of wood, such as discoloration, changes, issues, or cracks caused by alternating or excess humidity, etc.
- The warranty does not cover normal wear and tear of the product caused by its use and damage caused by incorrect installation or use is not compensated.
- The warranty does not cover damage caused by thunder or other weather phenomena.
- The warranty does not cover damage caused by incorrect installation by the client.
- The warranty expires when attempts are made to independently change or fix the product or if it is not used for its intended purpose.
- The warranty is void if the product is stored in an incorrect position or in the wrong conditions.
- The warranty is valid if the buyer informs the seller of the defect within a reasonable time (7 days).

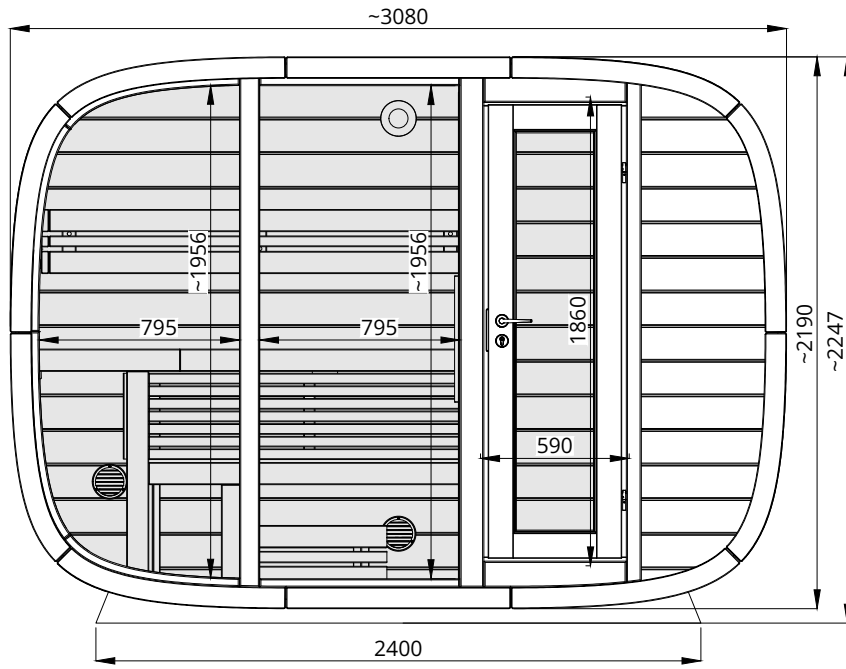

Front view

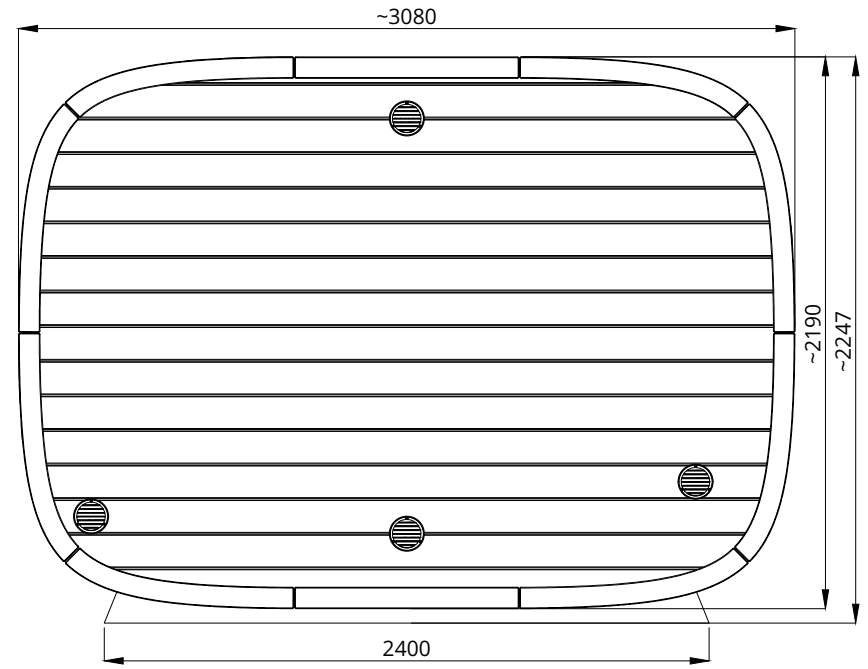

Back view

Round Cube (DOUBLE)		
Length	2.4	2.6
<b>a</b>	~2400 mm	~2600 mm
<b>b</b>	~2344 mm	~2544 mm
<b>c</b>	~896 mm	~996 mm

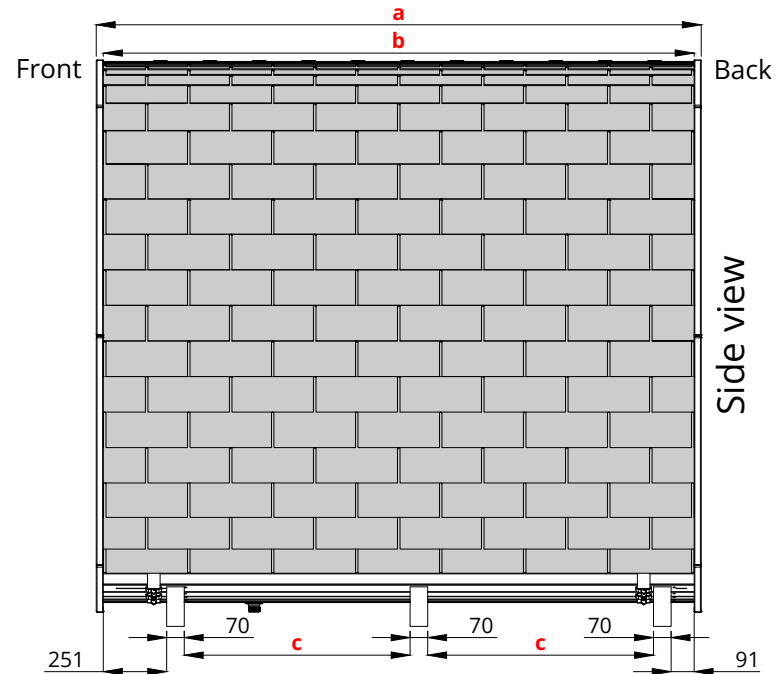

# Round Cube

(DOUBLE) 2.4 and 2.6

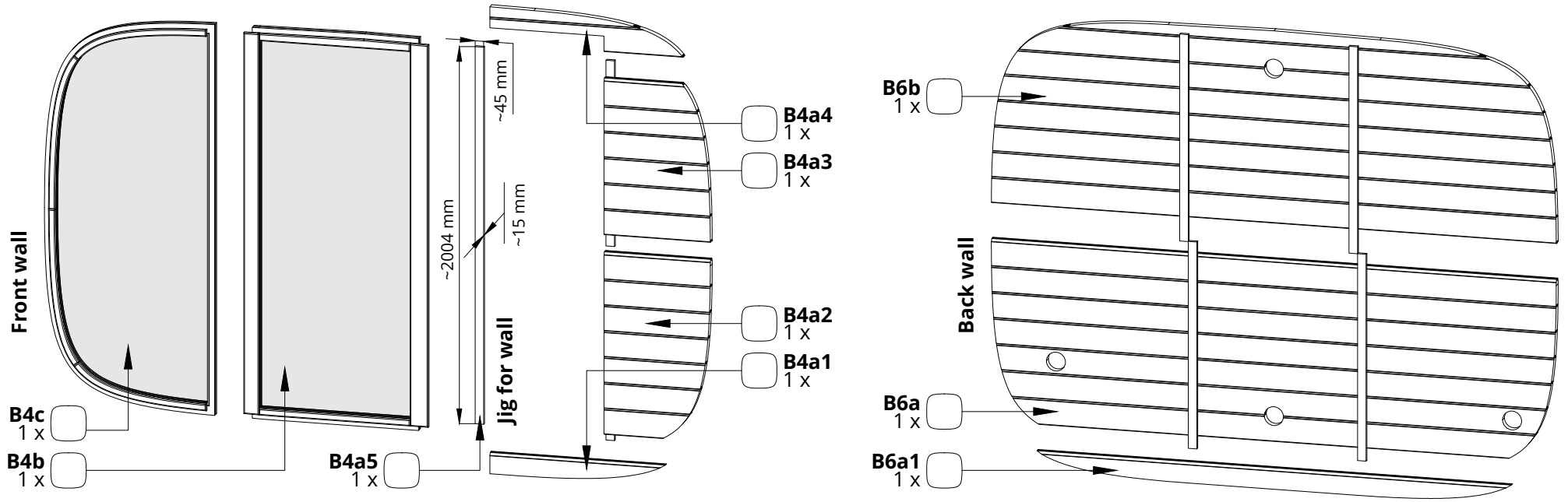



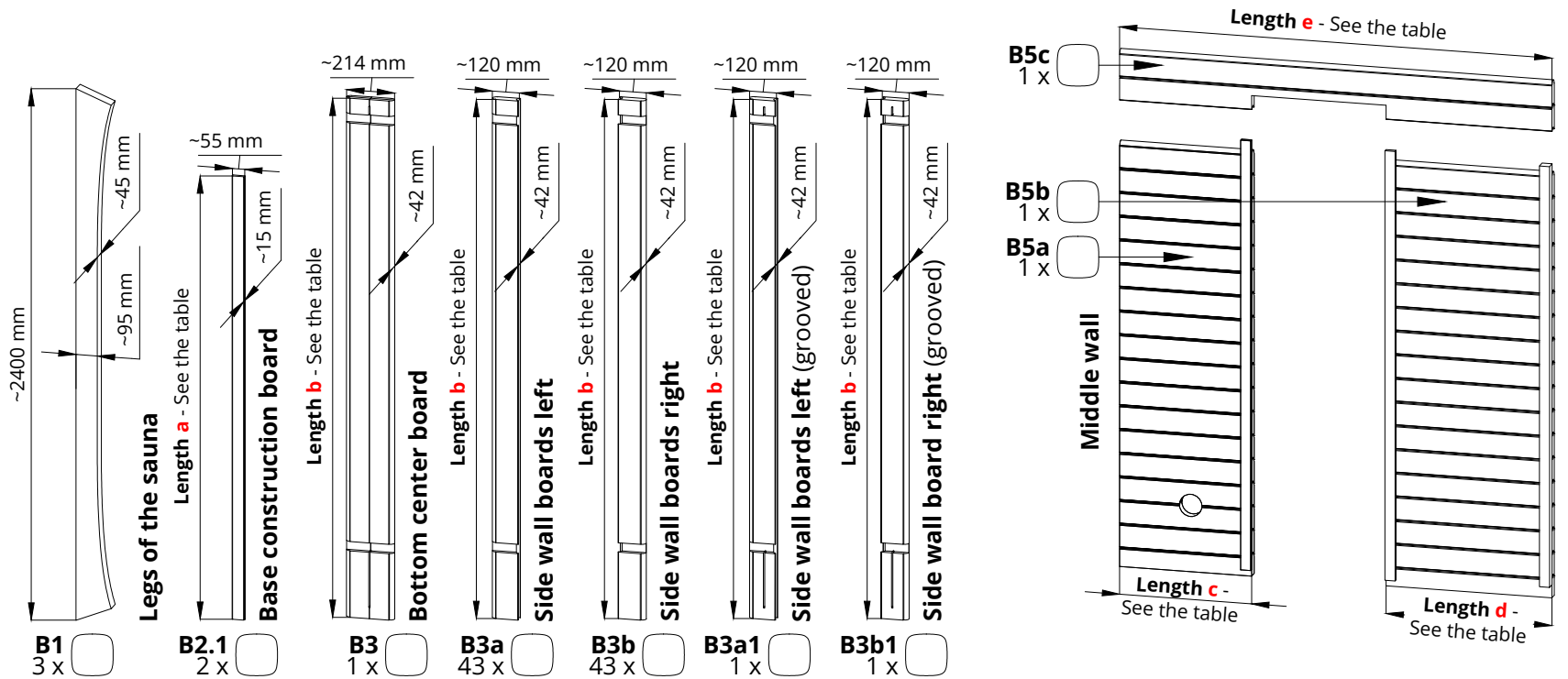

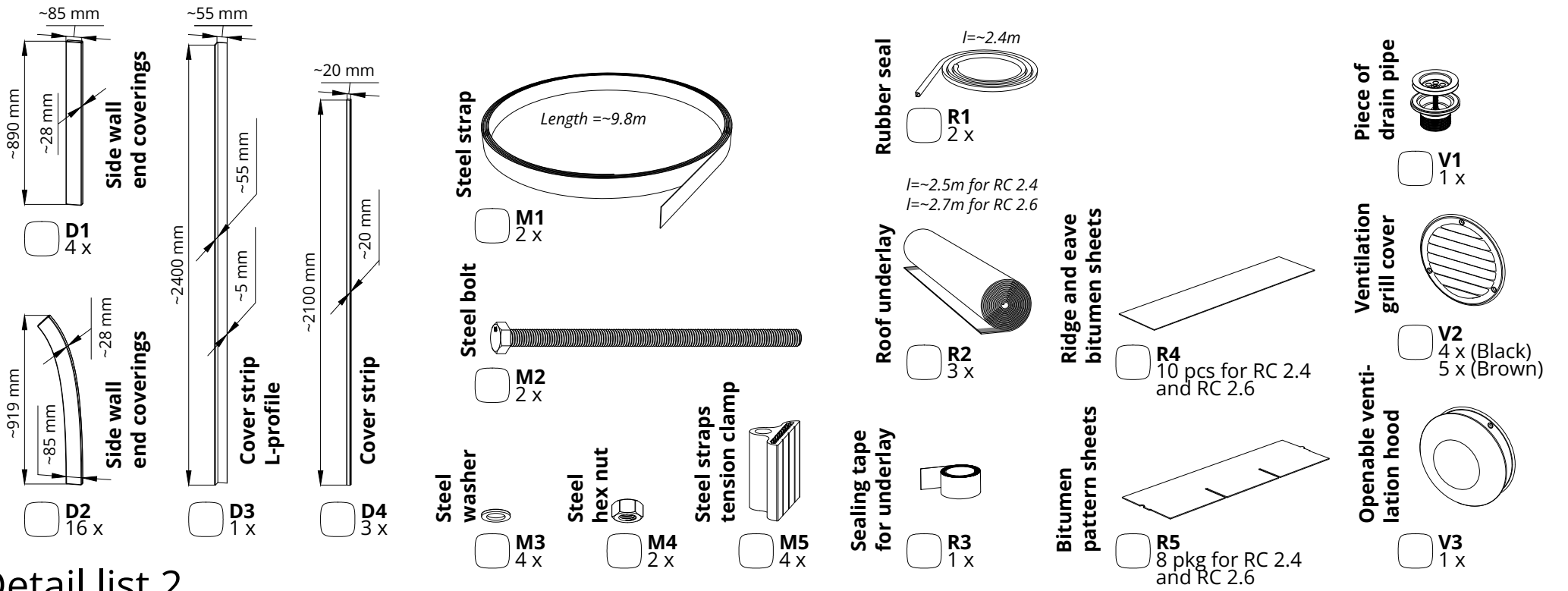
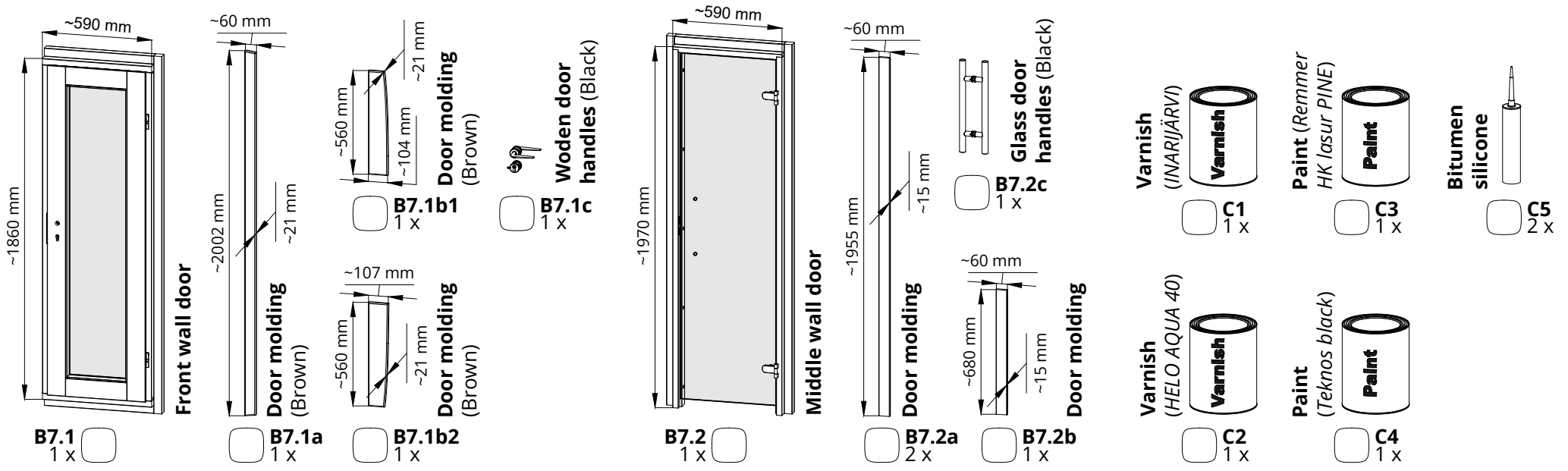

Round Cube (DOUBLE)		
Length	2.4	2.6
<b>a</b>	~2002 mm	~2202 mm
<b>b</b>	~2344 mm	~2544 mm
<b>c</b>	~590 mm	~690 mm
<b>d</b>	~741 mm	~841 mm
<b>e</b>	~1931 mm	~2131 mm

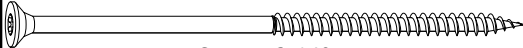

# Detail list 1

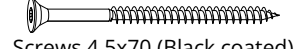
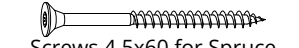
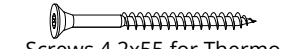
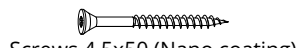
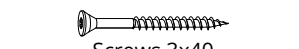
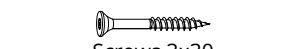
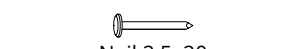
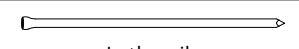

# Detail list 2

Name in manual	Nails and screws / Screw size (Scale 1:2)	Area of use	Quantity	
S9	 Screws 6x140	To fasten the walls	8	<input type="checkbox"/>
S7	 Screws 4,5x80 for Spruce	Mainly for construction inside and outside	120	<input type="checkbox"/>
	 Screws 4,2x75 for Thermo			
S6.2	 Screws 4,2x75	For fixing the door(s)	40	<input type="checkbox"/>
S6.1	 Screws 4,5x70 (Black coated)	For fixing the side wall end coverings	60	<input type="checkbox"/>
S5	 Screws 4,5x60 for Spruce	Mainly for construction inside and outside	160	<input type="checkbox"/>
	 Screws 4,2x55 for Thermo			
S3.2	 Screws 4,5x50 (Nano coating)	For fixing front wall and front wall door moldings	20	<input type="checkbox"/>
S2	 Screws 3x40	For fixing middle wall door moldings	20	<input type="checkbox"/>
S1	 Screws 3x30	Mainly for construction inside and outside	30	<input type="checkbox"/>
R6	 Nail 2,5x20	During roof installation	1kg	<input type="checkbox"/>
N1	 Lath nails	During cover strips installation	30	<input type="checkbox"/>
P	 Hole plug	For covering screw holes	26	<input type="checkbox"/>

## Detail list 3

S7	Screws 4,5x80 for Spruce Screws 4,2x75 for Thermo	6
		

NB! use a level

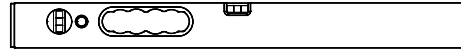

The base of the sauna must be level!

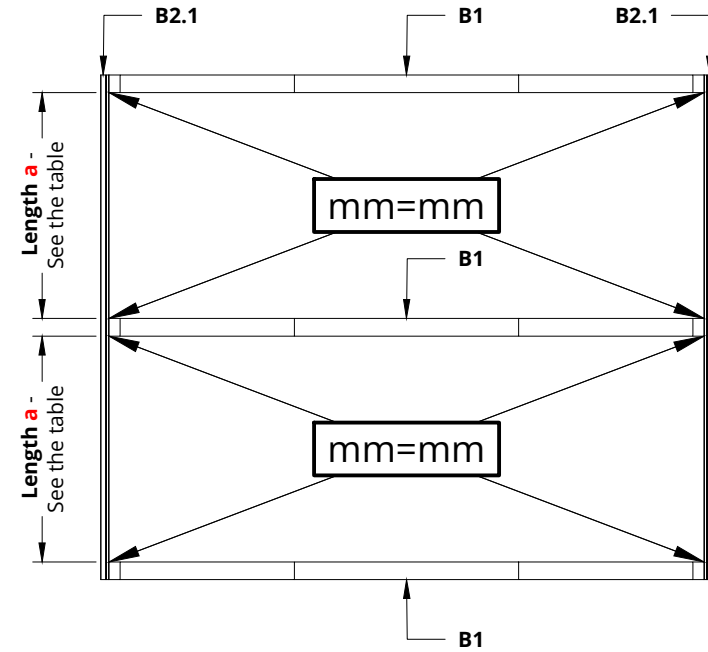
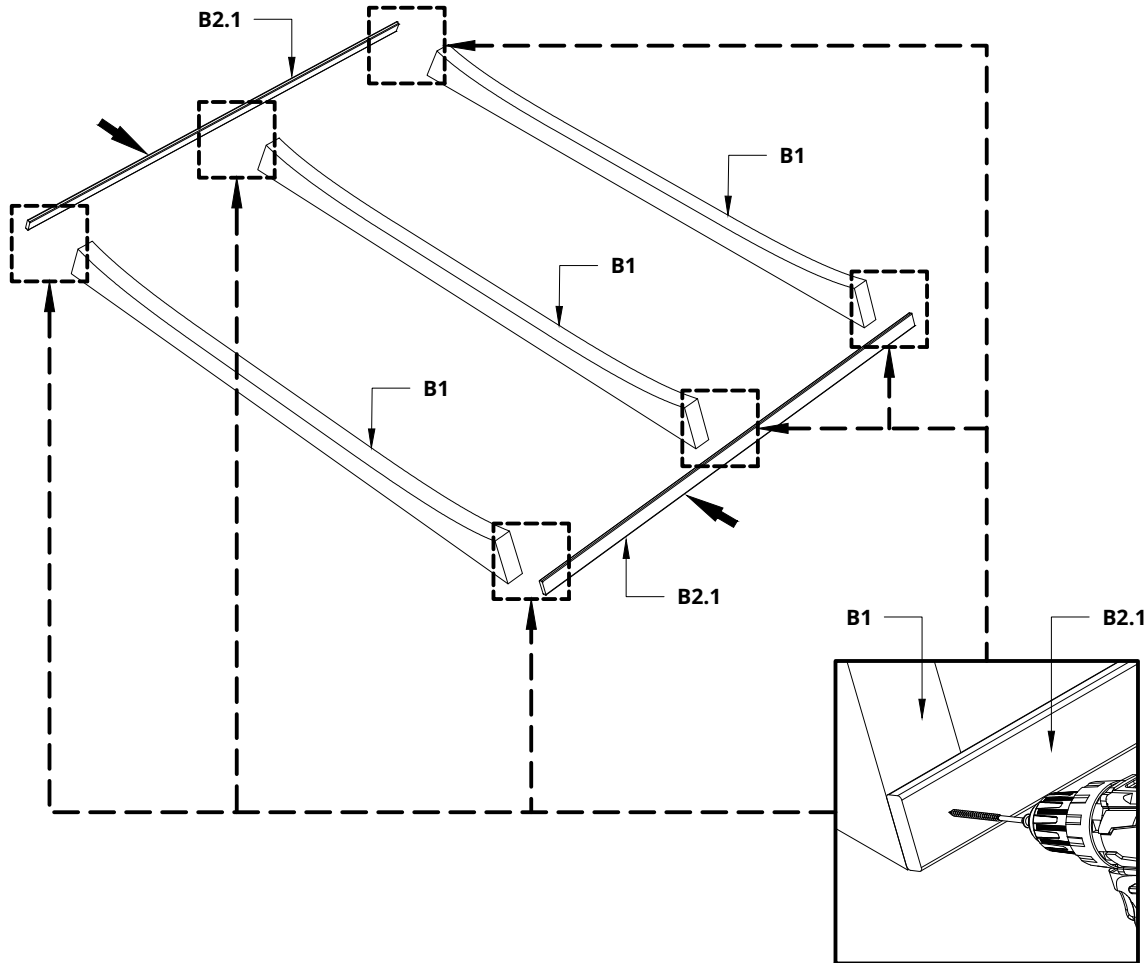



Round Cube (DOUBLE)		
Length	2.4	2.6
<b>a</b>	896 mm	996 mm

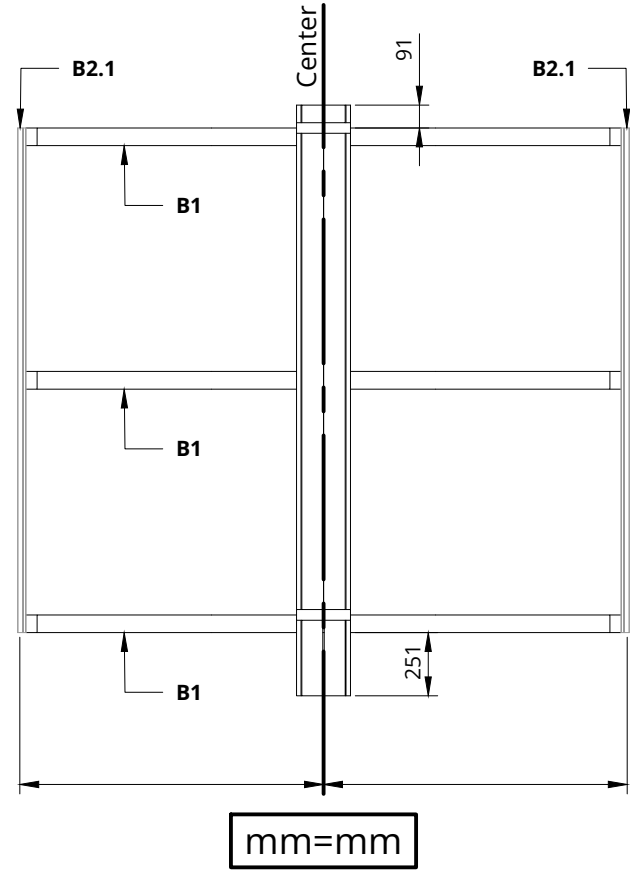
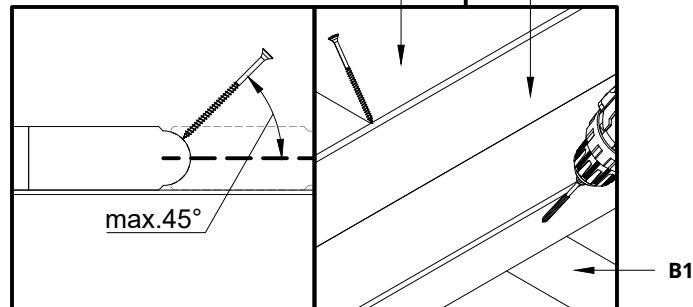
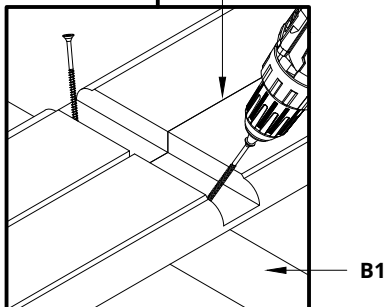
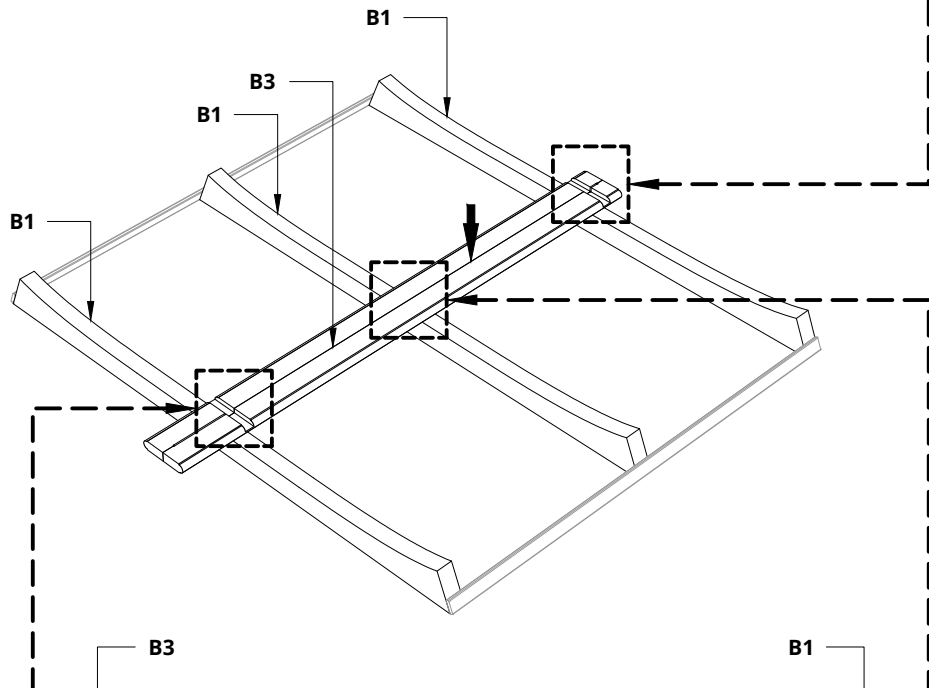
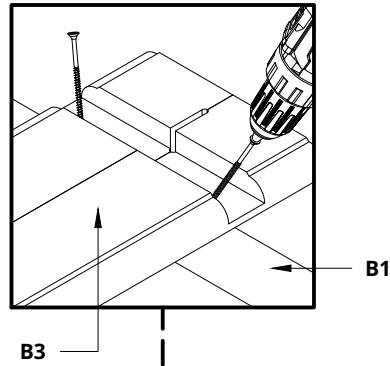

S7	Screws 4,5x80 for Spruce Screws 4,2x75 for Thermo	6
		

**Please countersink the screw head(s)!**



S7	Screws 4,5x80 for Spruce Screws 4,2x75 for Thermo	58
		

**Please countersink the screw head(s)!**  
**Use a rubber mallet to tap the planks together!**  
**Drill 10 mm hole in each plank groove!**

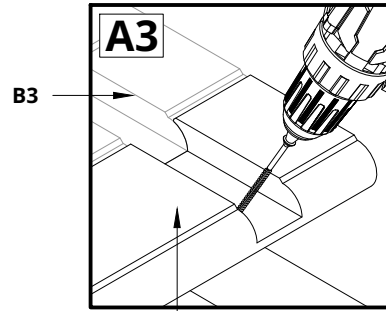

B3a Left and  
B3b Right

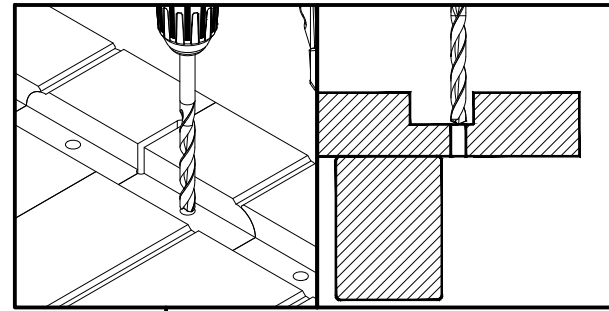

B3a1 Left and  
B3b1 Right

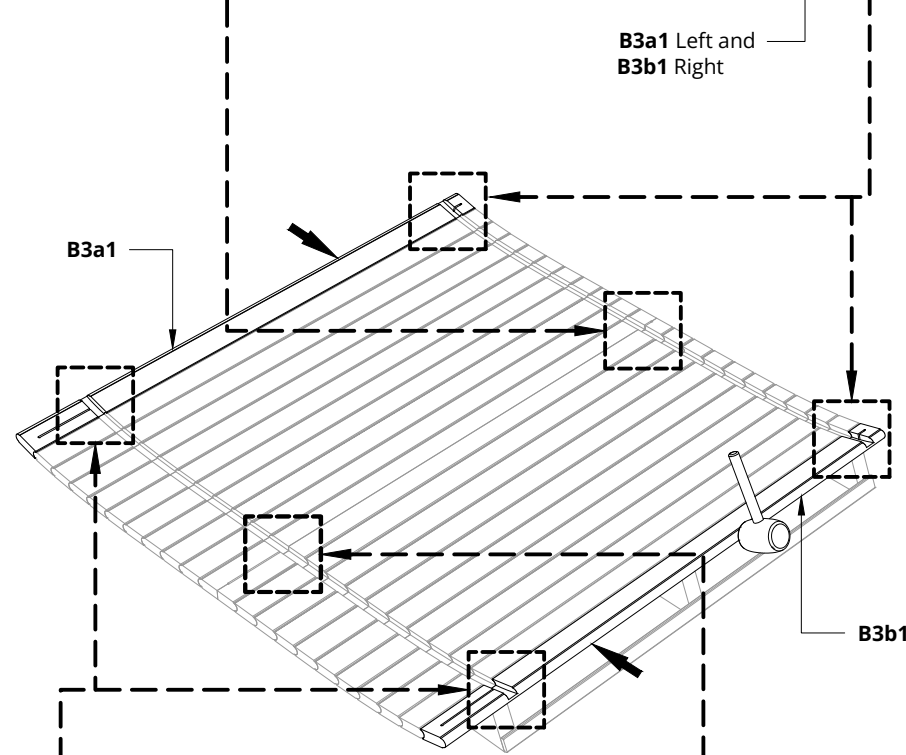
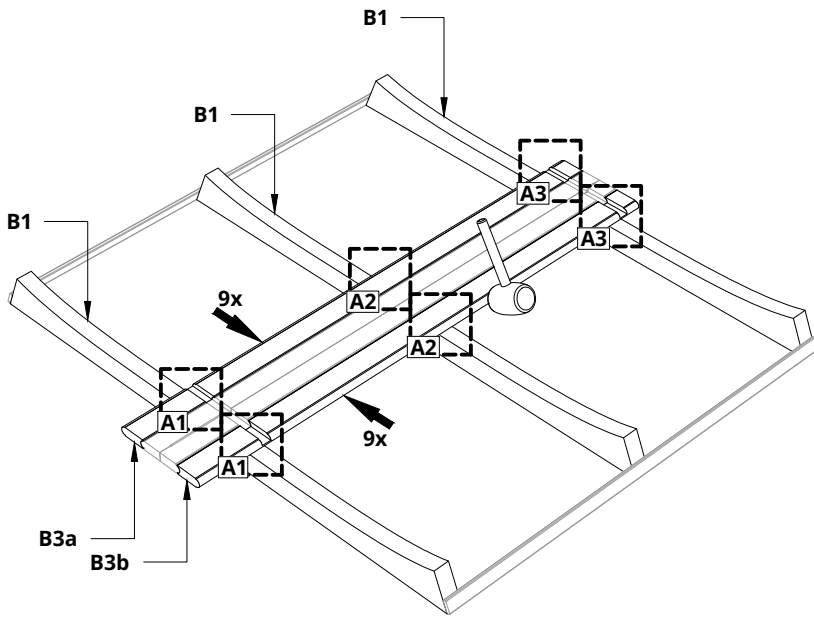
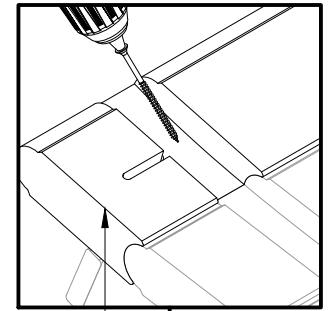

B3a Left and  
B3b Right

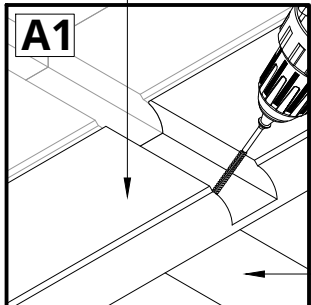

B3a Left and  
B3b Right

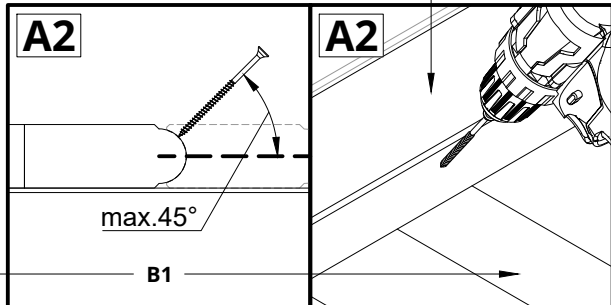

B3a1 Left and  
B3b1 Right

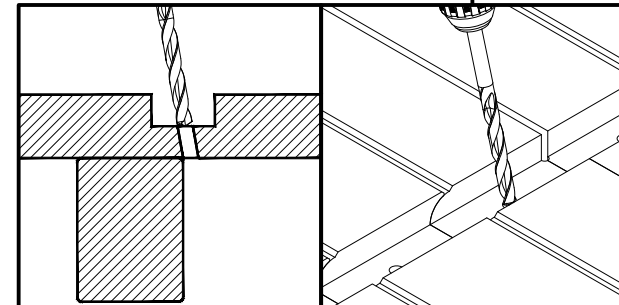
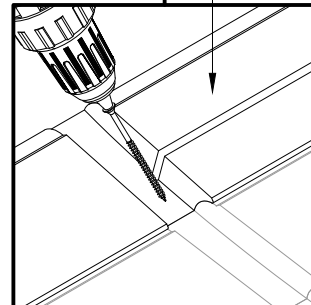

**Cut a hole for the drain pipe!**  
**Clean the groove and floor surfaces from wood waste and other dirt!**  
**Cover the grooves and the floor surfaces (middle) with varnish by following the manufacturer's instructions!**  
**Paint the front end and back end of the boards!**

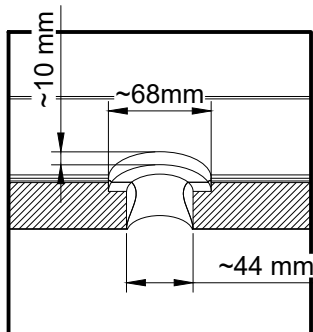
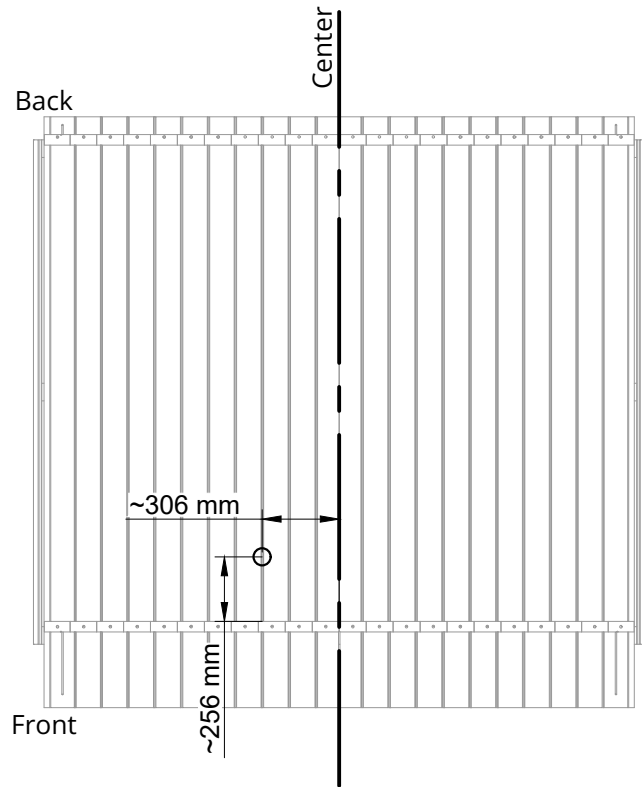

**C3**  
Add two coats of paint  
(Remmer HK lasur PINE)

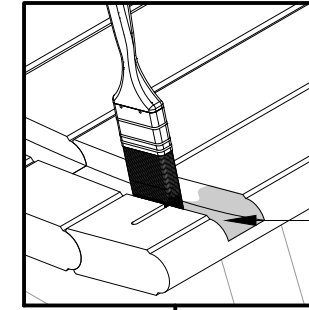
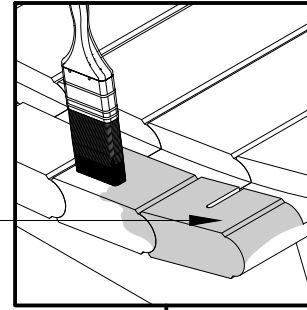

**C1**  
Add two coats  
of varnish  
(INARIJÄRVI)

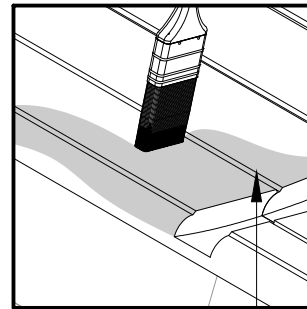
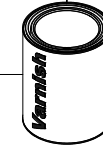

**C2**  
Add two or three  
coats of varnish  
(HELO AQUA 40)

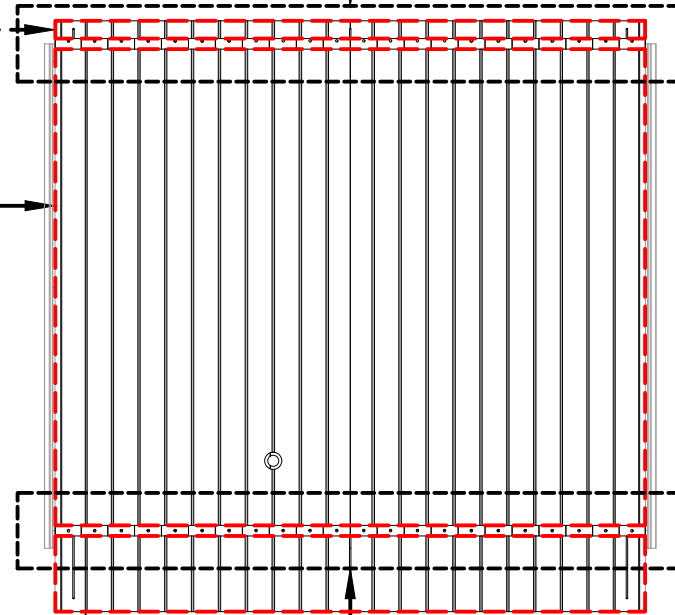

**C3**  
Add two coats of paint  
(Remmer HK lasur PINE)

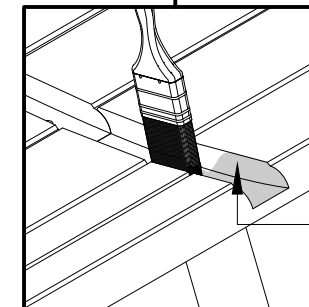
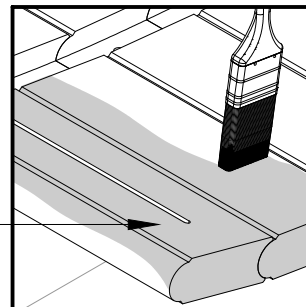

**C1**  
Add two coats  
of varnish  
(INARIJÄRVI)

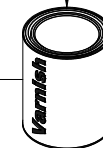

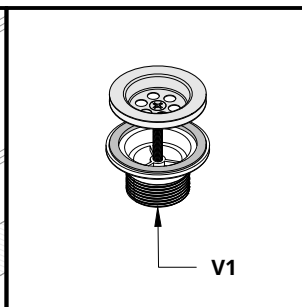
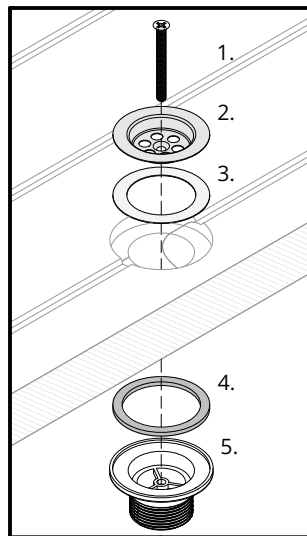

S7	Screws 4,5x80 for Spruce Screws 4,2x75 for Thermo	2
		

Lift the bottom of the sauna up on one side and install some aids!  
Clean the bottom surface!  
Cover the surface with paint (black), let the paint dry!  
Install a piece of drain pipe V1.  
Install the rubber seal R1!  
Remove boards B2.1!

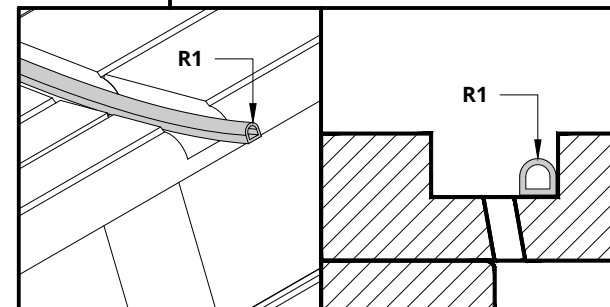
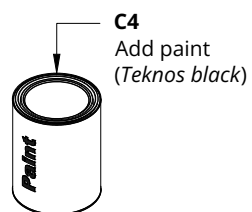
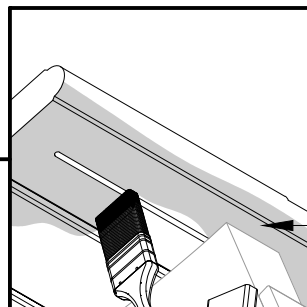
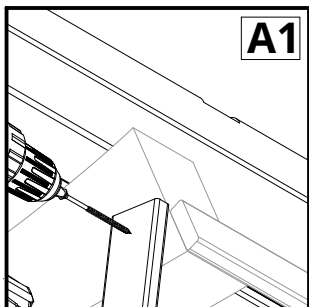
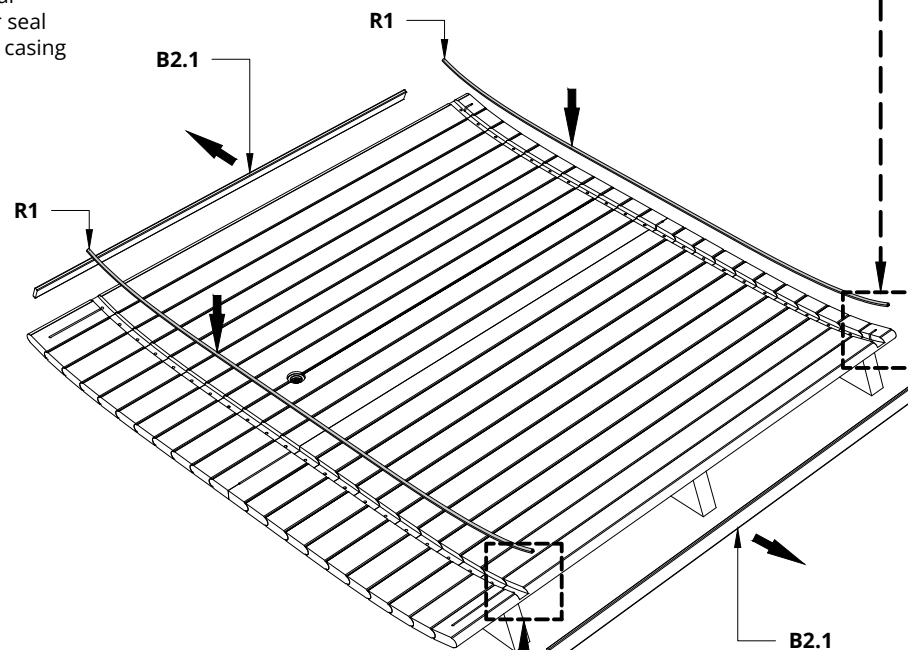
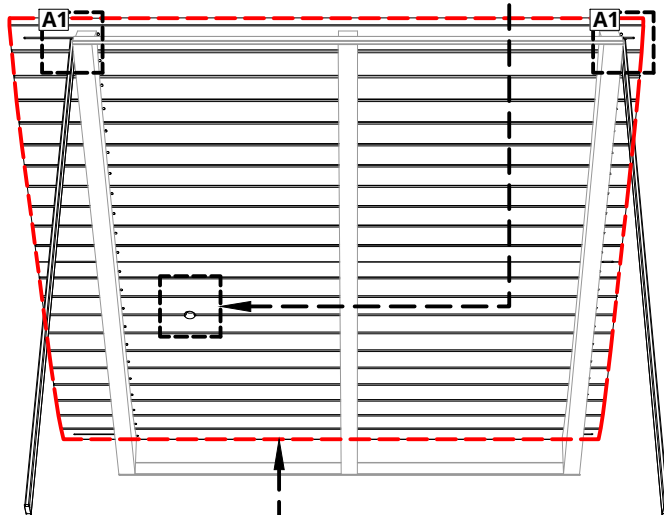
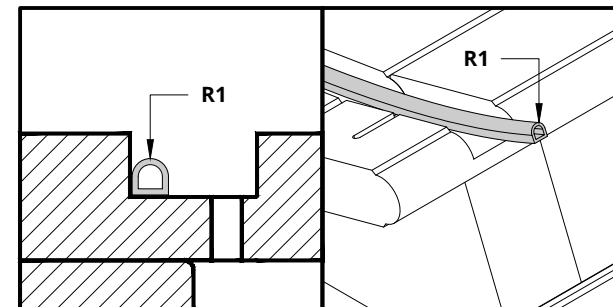

1. Bolt
2. Sieve
3. Soft seal
4. Rubber seal
5. Siphon casing



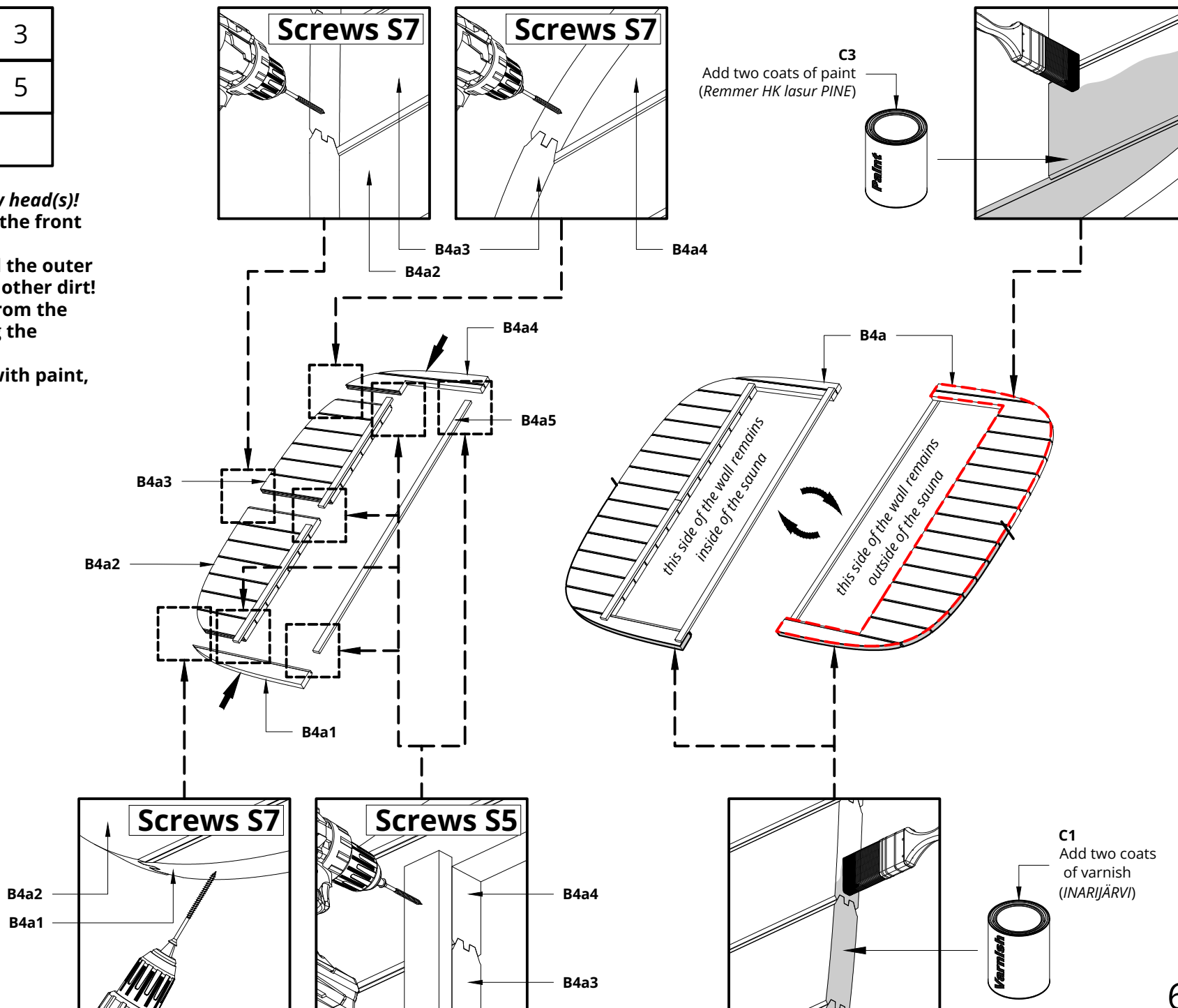
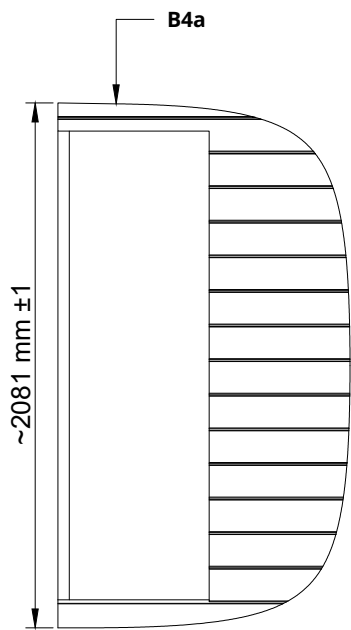

S7	Screws 4,5x80 for Spruce Screws 4,2x75 for Thermo	3
S5	Screws 4,5x60 for Spruce Screws 4,2x55 for Thermo	5
		

**Please countersink the S7 screw head(s)!**  
**Assemble the wooden part of the front wall!**  
**Clean the edge of the wall and the outer surface from wood waste and other dirt!**  
**Varnish the edge of the wall from the bottom to middle by following the manufacturer's instructions!**  
**Cover the wall outer surface with paint, let the paint dry!**

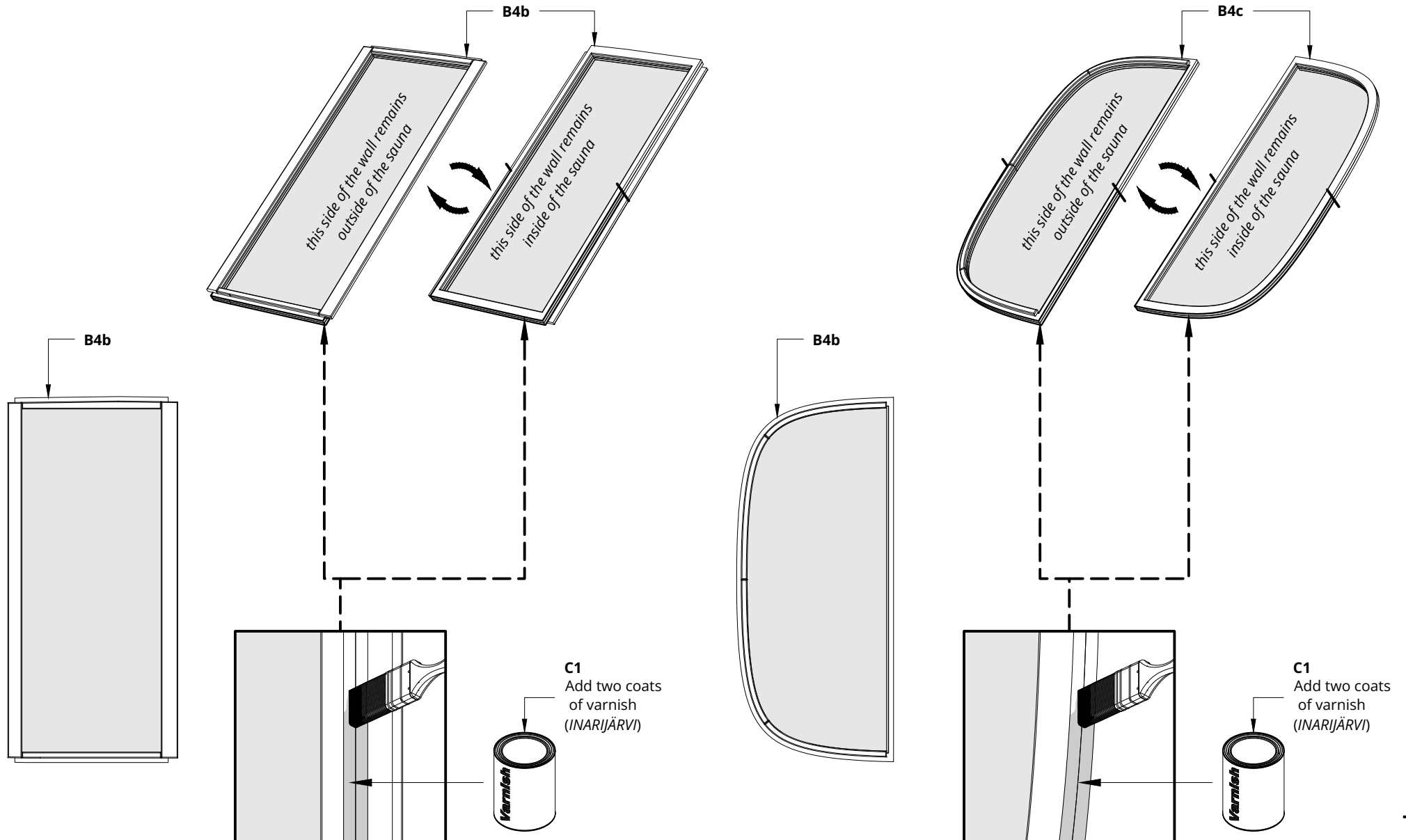

Clean the edges of the walls and the outer surfaces from wood waste and other dirt!  
Varnish the edges of the walls from the bottom to middle by following the manufacturer's instructions!



S7	Screws 4,5x80 for Spruce Screws 4,2x75 for Thermo	2
S5	Screws 4,5x60 for Spruce Screws 4,2x55 for Thermo	2
		

**Please countersink the S7 screw head(s)!**  
**Assemble the lower part of the back wall!**  
**Clean the edge of the lower part of the back wall and the outer surface from wood waste and other dirt!**  
**Varnish the edge of the lower part of the back wall from the bottom to middle by following the manufacturer's instructions!**  
**Cover the lower part and upper part of the back wall outer surface with paint, let the paint dry!**

**C3**  
 Add two coats of paint  
 (Remmer HK lasur PINE)

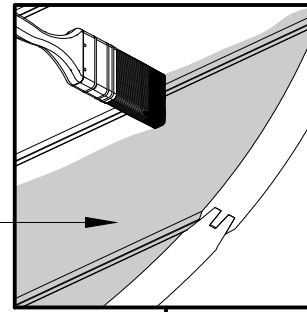

**C3**  
 Add two coats of paint  
 (Remmer HK lasur PINE)

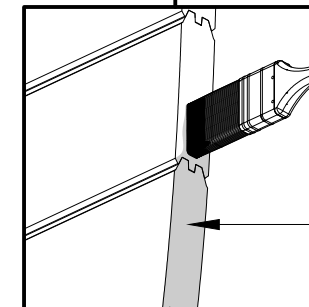
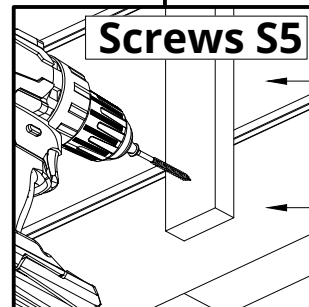
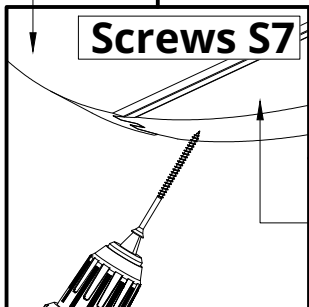
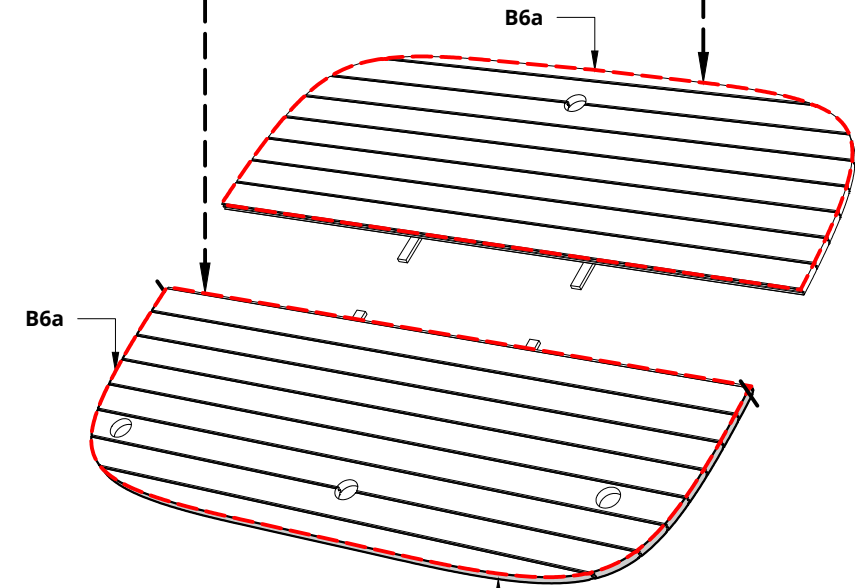
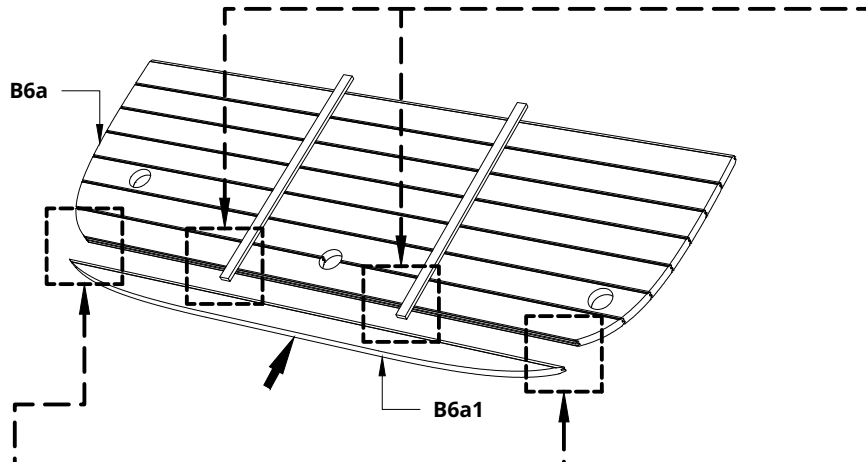
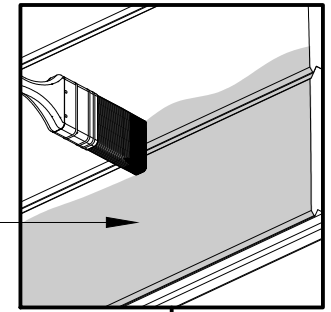

**C1**  
 Add two coats  
 of varnish  
 (INARIJÄRVI)



Disassemble the parts of the middle wall, for the future construction of the sauna!  
Label the piece accordingly!  
Clean front and bottom edge of the middle wall from wood waste and other dirt!  
Varnish the edges of the middle wall parts by following the manufacturer's instructions!

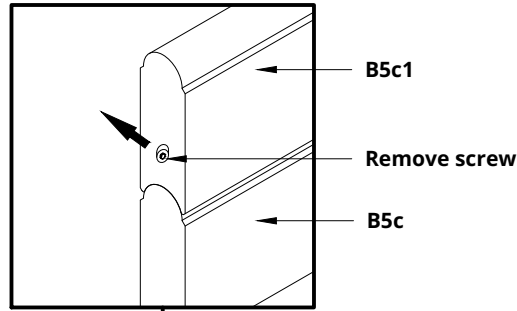

C1  
Add two coats  
of varnish  
(INARIJÄRVI)

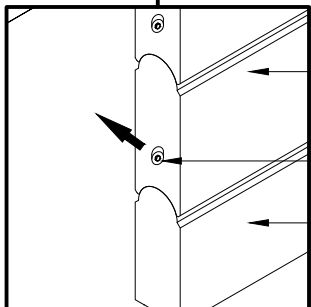
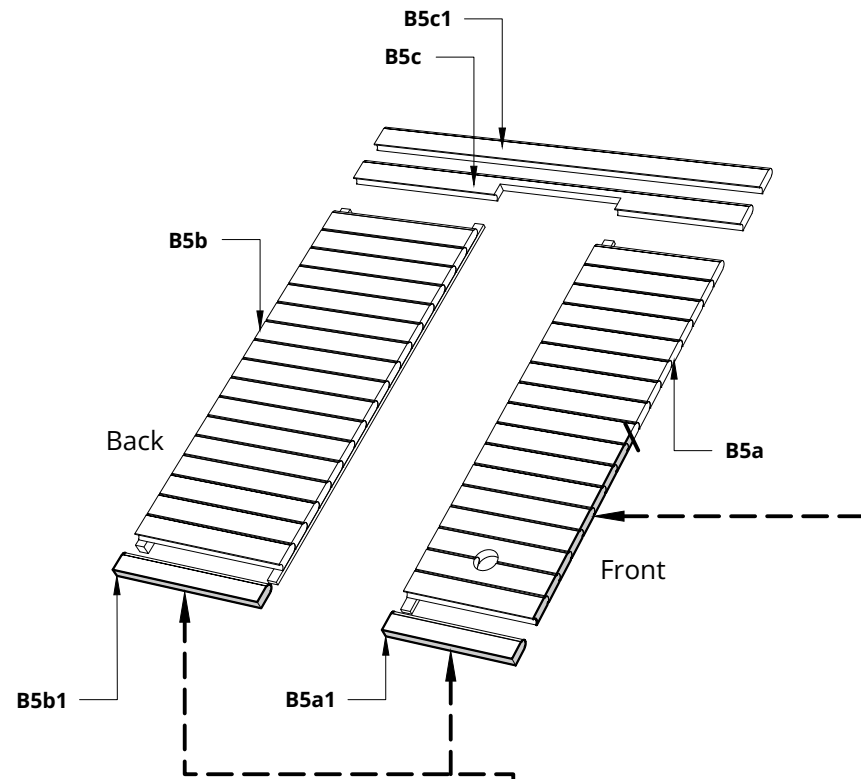
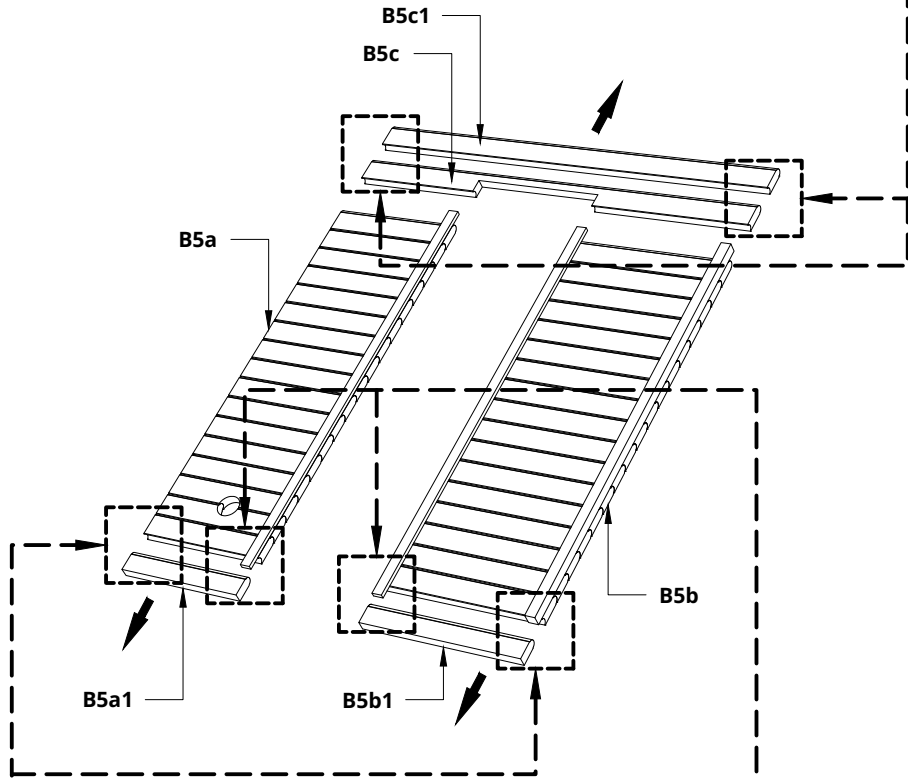
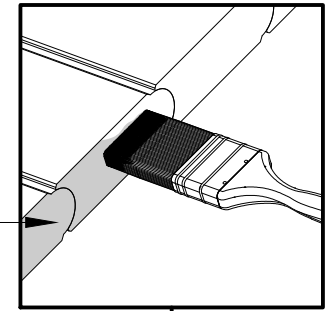
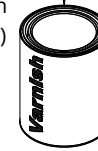

B5a and B5b  
Remove screw  
B5a1 and B5b1

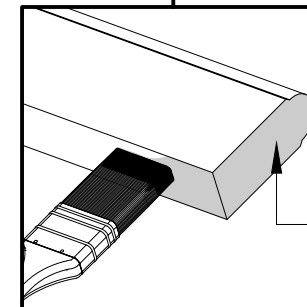
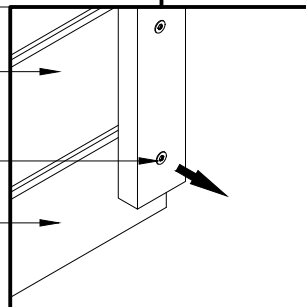

C1  
Add two coats  
of varnish  
(INARIJÄRVI)







**Preparation for side wall boards.**

Before doing the processes, clean the sidewall boards from wood waste and other dirt!

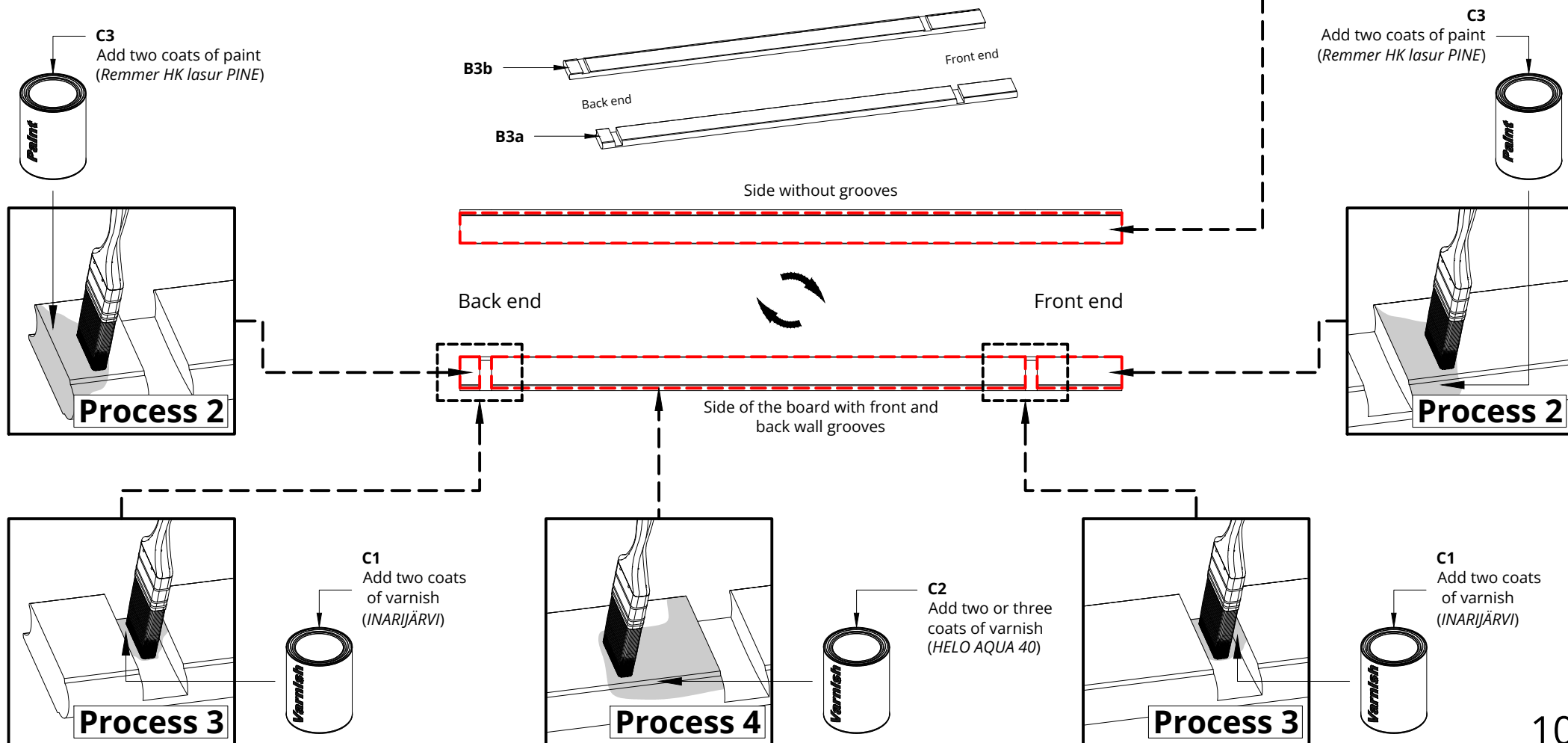
Boards	First ones		The following ones					
	B3a	B3b	B3a	B3b	B3a	B3b	B3a	B3b
Process 1	✓	✓	✗	✗	✗	✗	✗	✗
Process 2	✓	✓	✓	✓	✓	✓	✓	✓
Process 3	✓	✓	✓	✓	✓	✓	✗	✗
Process 4	✓	✓	✓	✓	✗	✗	✗	✗
Label them	1L	1R	2L	2R	3L	3R	4L	4R
Quantity	2	2	3	3	6	6	33	33



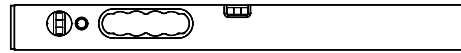

S9	Screws 6x140	4
S5	Screws 4,5x60 for Spruce Screws 4,2x55 for Thermo	2
		

NB! use a level

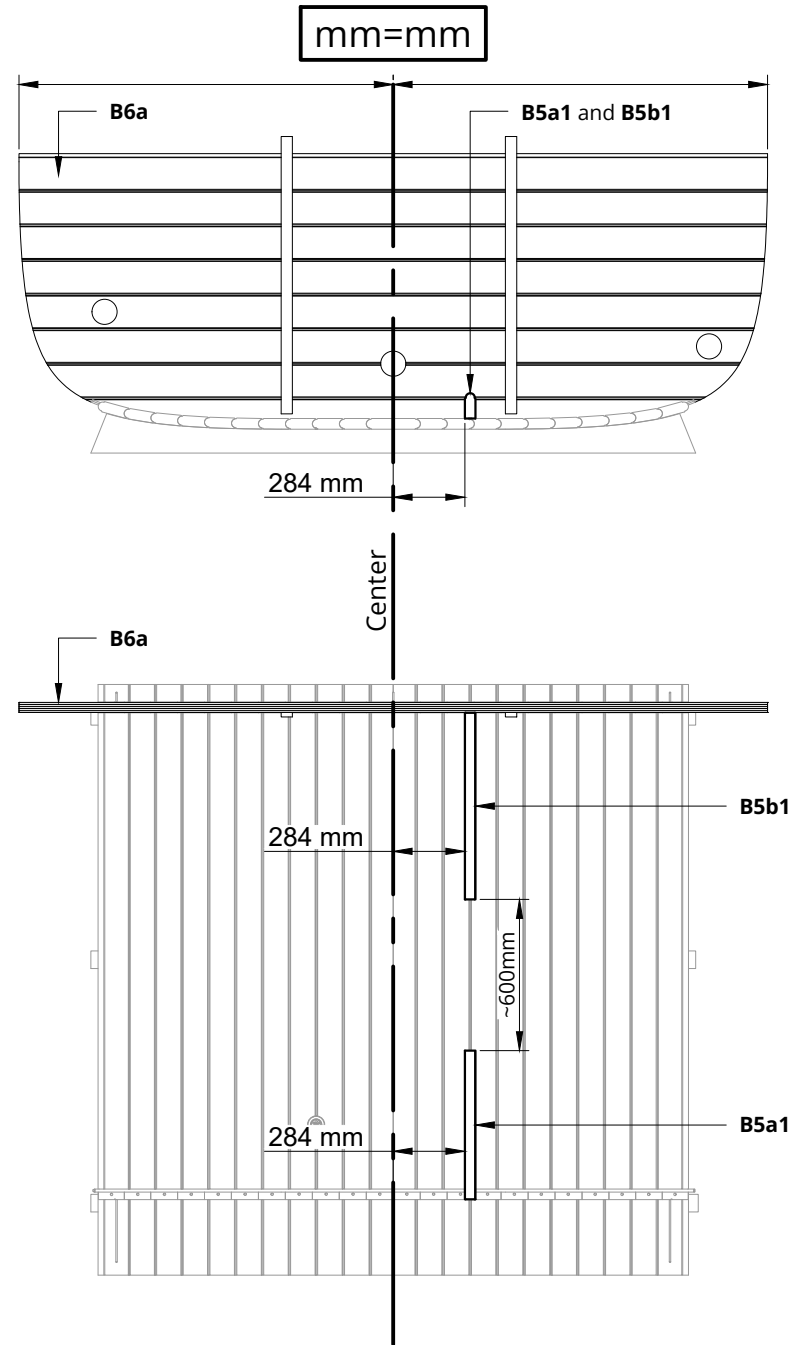
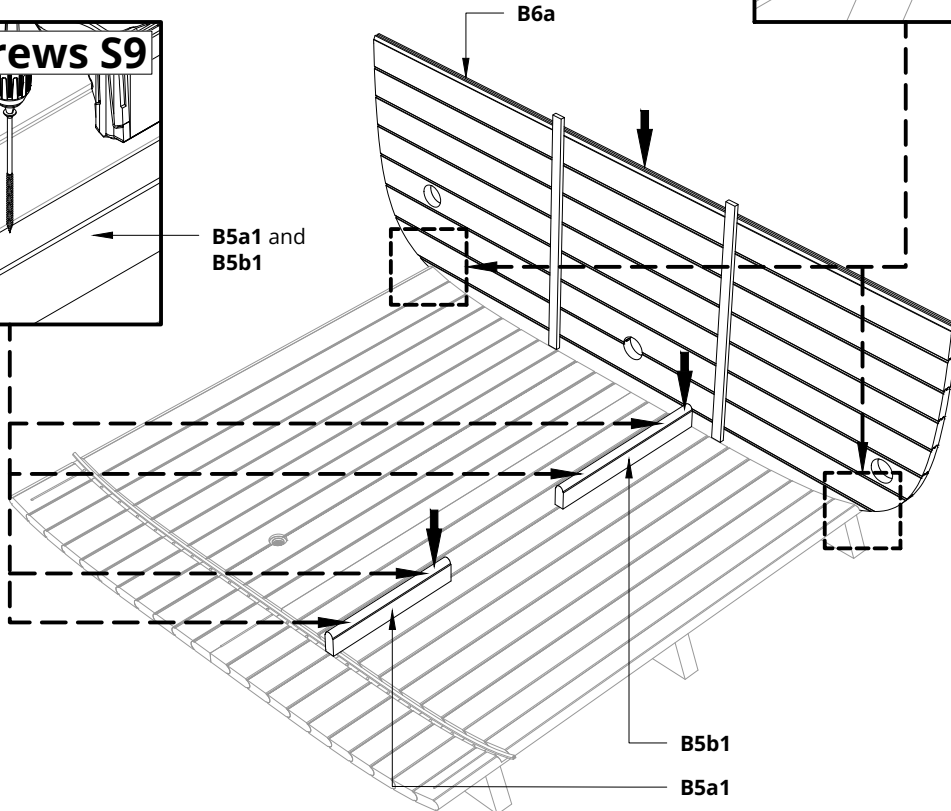
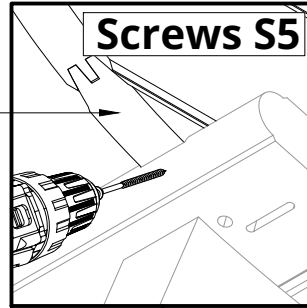
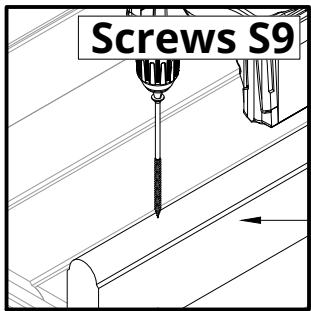

**Please countersink the screw head(s)!**  
**Make sure that the lower part of the back wall are centered in relation to the bottom!**  
**Install the lower part of the back wall B6a first!**  
**Drill small holes in the middle wall parts B5a1 and B5b1 for the screws!**



S9	Screws 6x140	2
S7	Screws 4,5x80 for Spruce Screws 4,2x75 for Thermo	10
S5	Screws 4,5x60 for Spruce Screws 4,2x55 for Thermo	4
		

NB! use a level

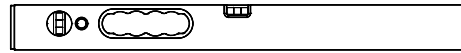

**Please countersink the S7 and S9 screw head(s)!**  
**Install the middle wall part B5b first!**  
**Drill small holes in the middle wall part B5c for the screws!**

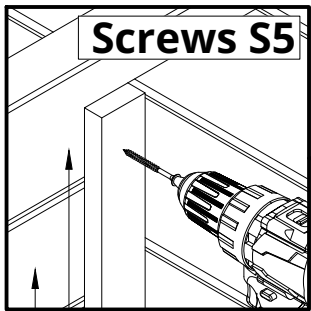

**Screws S5**

B5c  
 B5a and B5b  
 B5a1 and B5b1

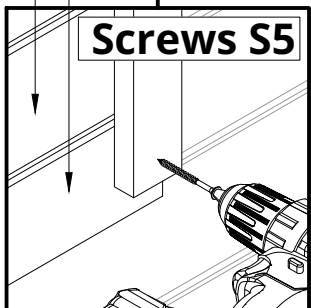

**Screws S5**

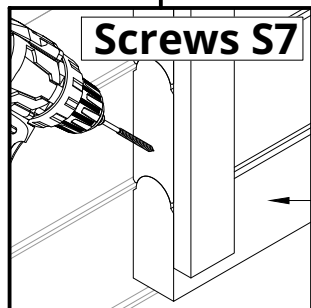

**Screws S7**

B5a1 and B5b1

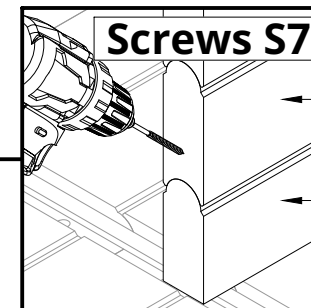

**Screws S7**

B5a  
 B5a1

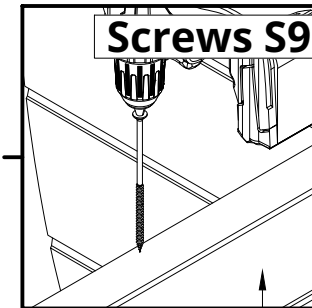

**Screws S9**

B5c

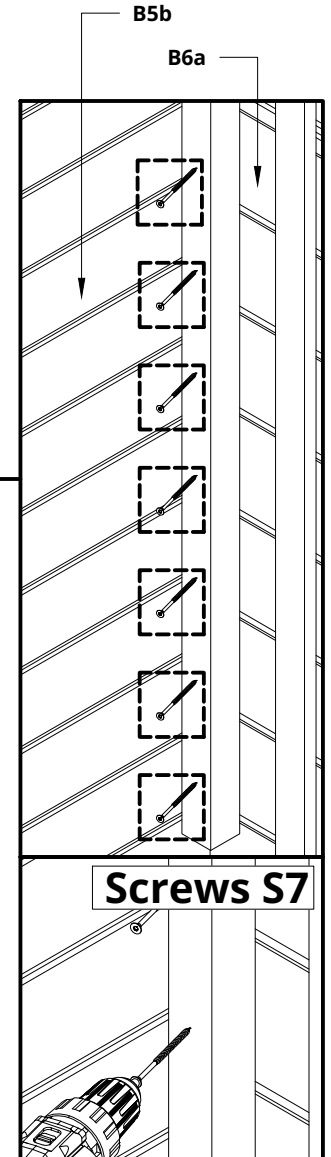

B5b  
 B6a

**Screws S7**

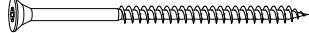
S7	Screws 4,5x80 for Spruce Screws 4,2x75 for Thermo	28
S5	Screws 4,5x60 for Spruce Screws 4,2x55 for Thermo	1
S3.2	Screws 5x40 (Nano coating)	5
		

NB! use a level

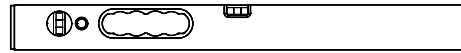

**Please countersink the screw head(s)!**  
**Install the upper part of the back wall B6b first!**  
**Install the glass wall part of the front wall B4b!**  
**Remove the back wall connection strips!**

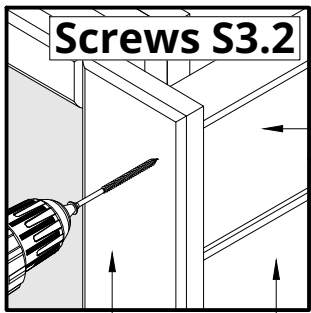

B4b B5a

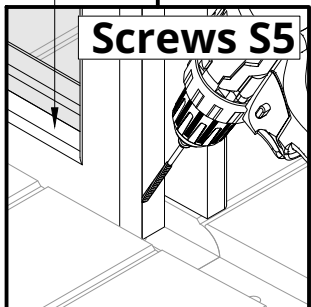

B4b

B5a

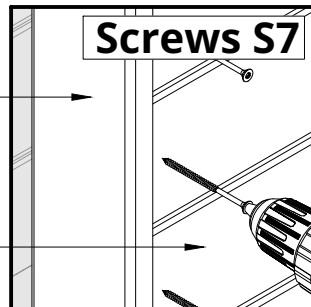

Screws S7

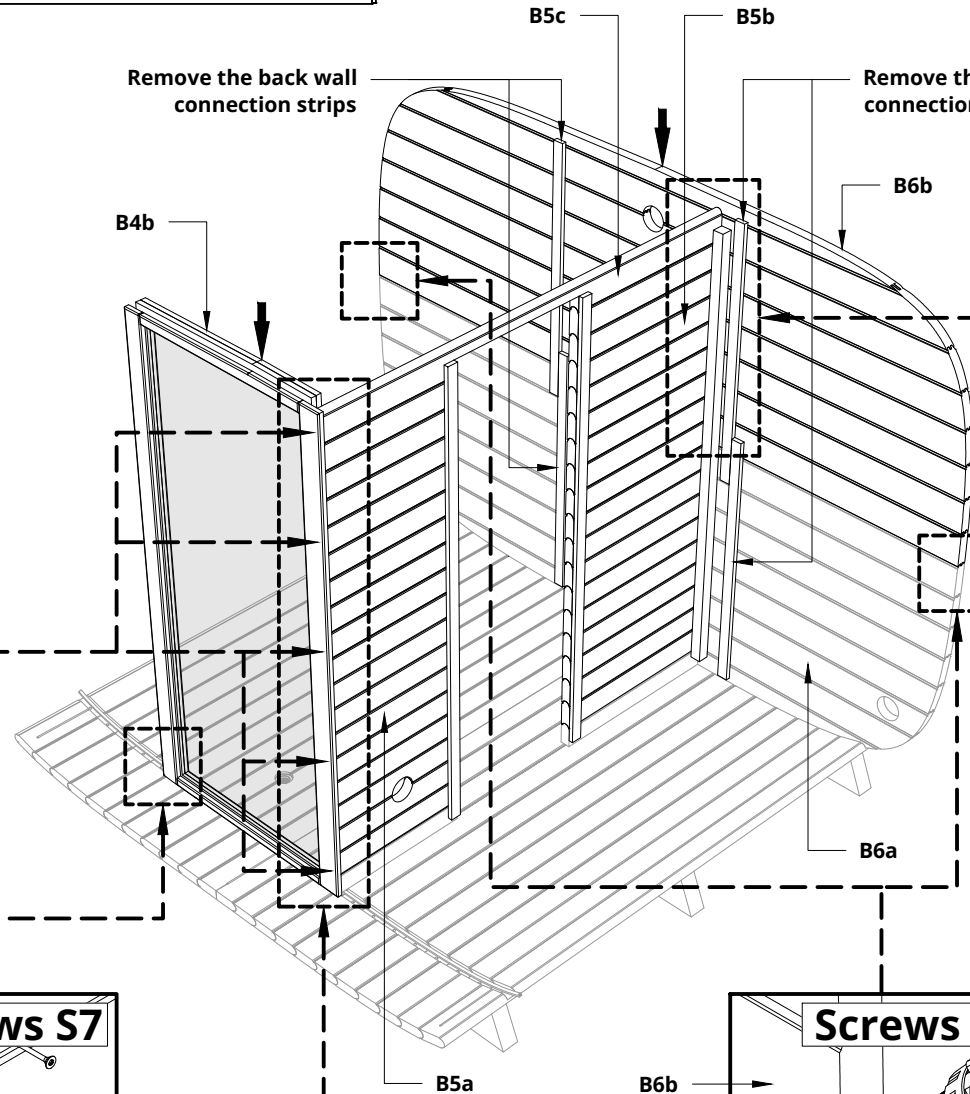

Remove the back wall connection strips

Remove the back wall connection strips

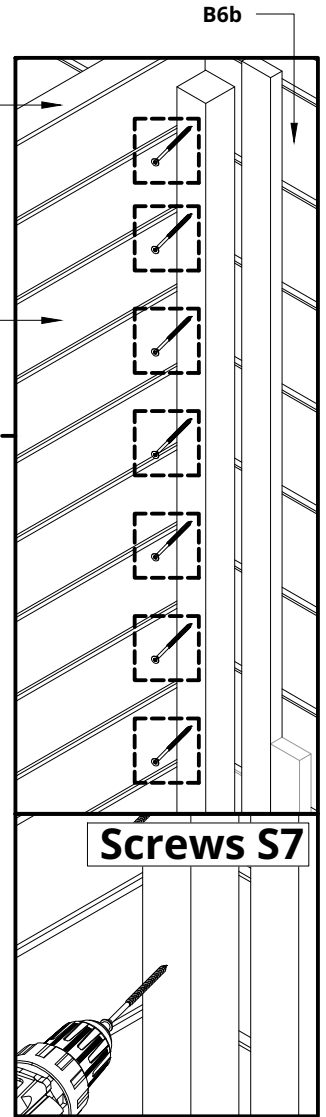

Screws S7

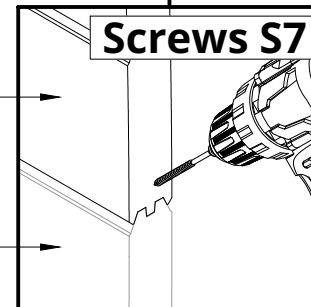

B6b

B6a

**Attention! If the gap is 25 mm, the following steps do not need to be performed and B5c1 does not need to be installed either.**

**Measure the gap front and back, the dimensions can be different!**

Subtract 25mm from the length and transfer the measurements to the plank. Connect the dimensions on the plank with a line.

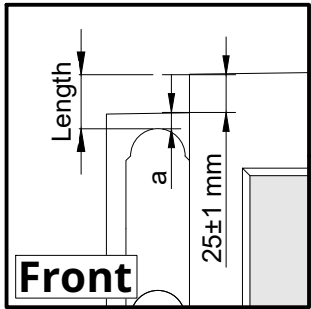

*Front measurement.*

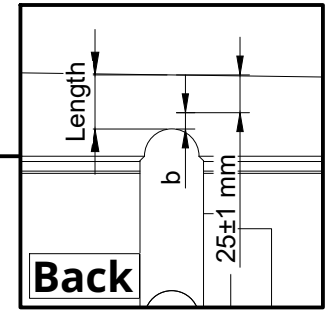
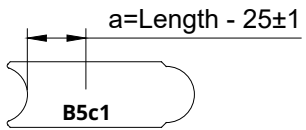

*Back measurement.*

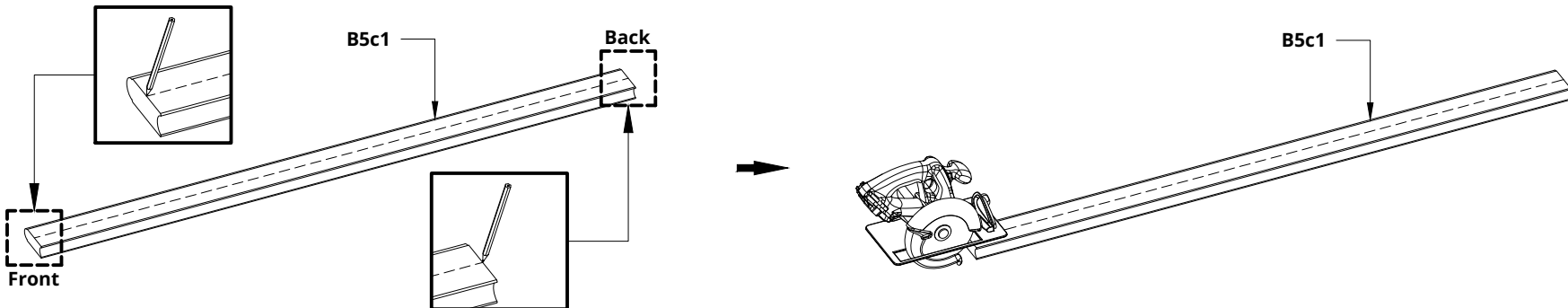
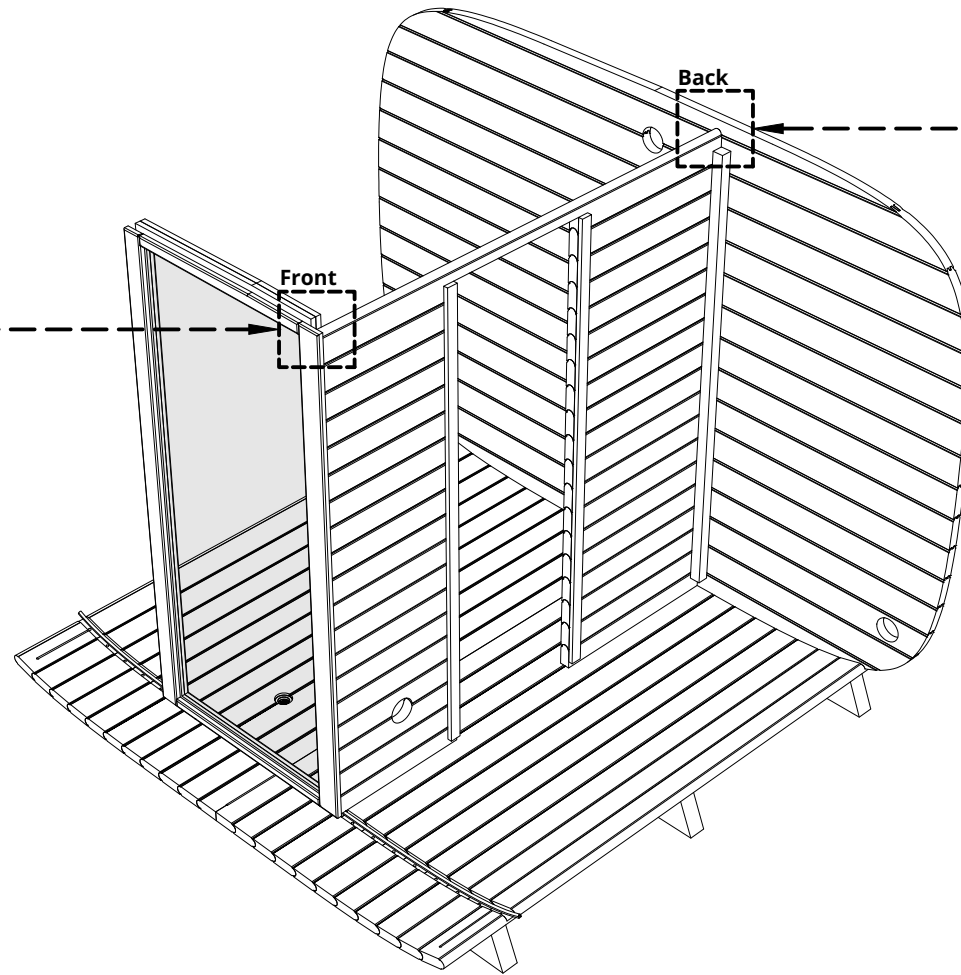
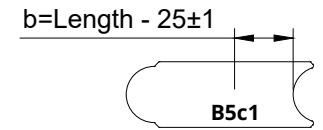

S5	Screws 4,5x60 for Spruce Screws 4,2x55 for Thermo	6
S3.2	Screws 5x40 (Nano coating)	5
		

**Please countersink the screw head(s)!  
Drill small holes in the middle wall part  
B5c1 for the screws before installing!  
Install the glass wall part of the front  
wall B4c!  
Remove the middle wall connection  
strips!**

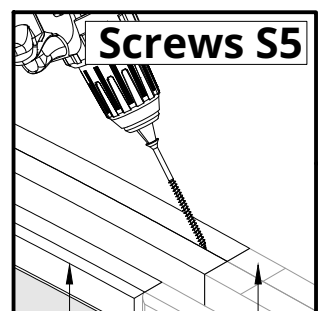
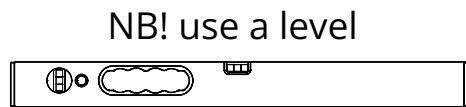

B4c B4b

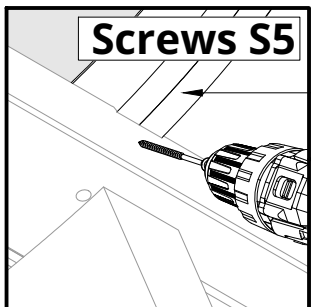

B4c

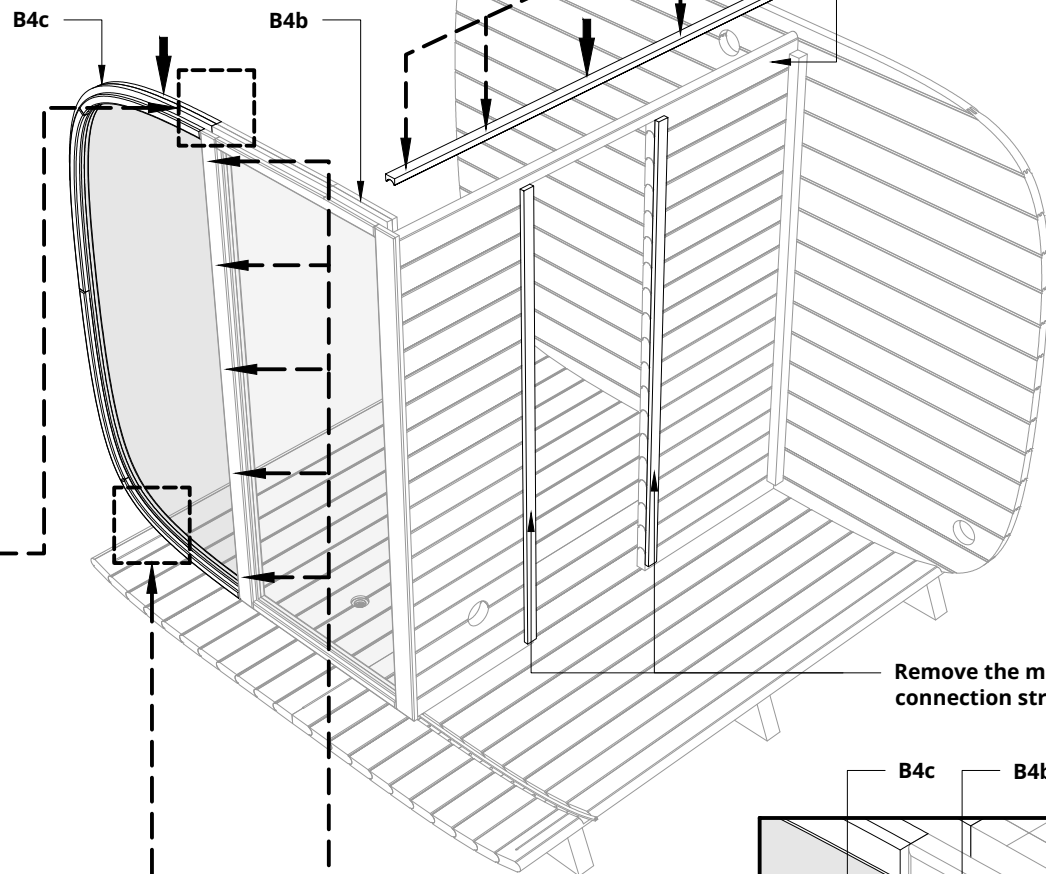

Remove the middle wall  
connection strips

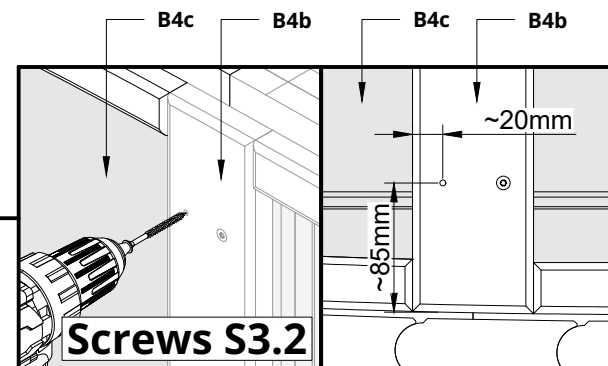
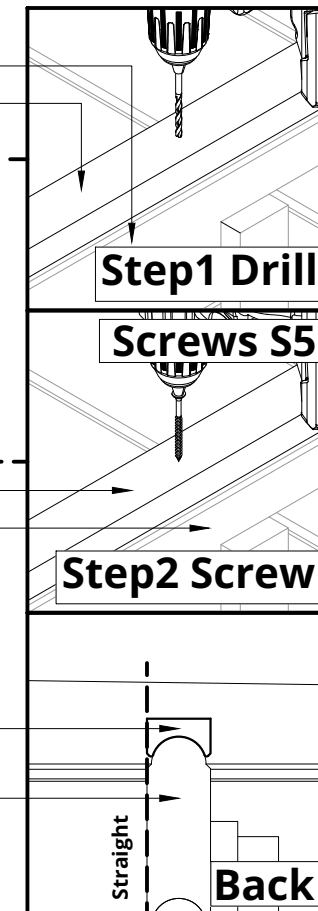

**Screws S3.2**

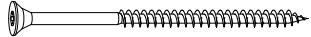
S9	Screws 6x140	1
S7	Screws 4,5x80 for Spruce Screws 4,2x75 for Thermo	2
S5	Screws 4,5x60 for Spruce Screws 4,2x55 for Thermo	6
		

**Please countersink the S7 and S9 screw head(s)!**  
**Install safety board (B3a or B3b) labeled as (4L or 4R)!**  
**Install the front wall part B4a and piece of wood (cut it from removed connection strips)!**  
**Drill small holes in the front wall part B4a for the S9 screw!**

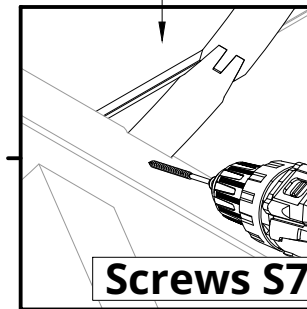
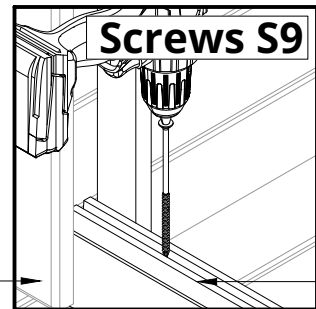
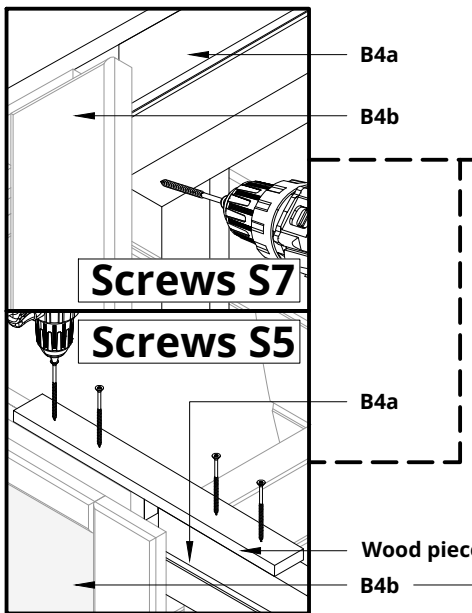
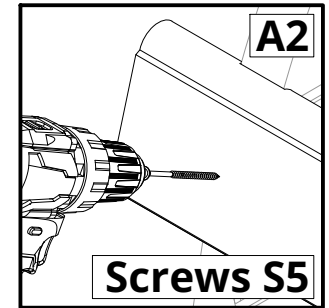
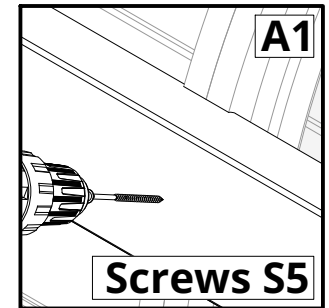
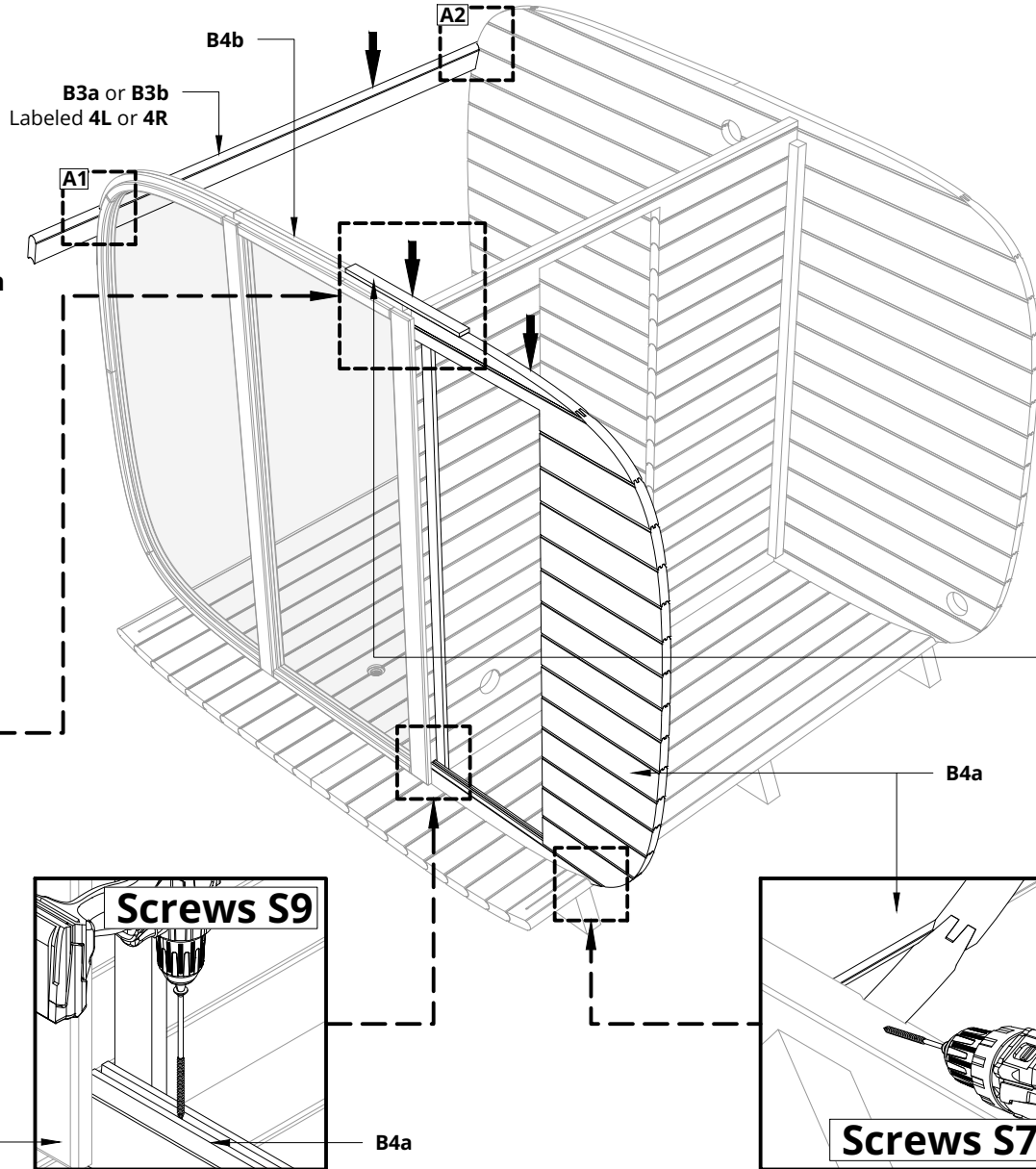
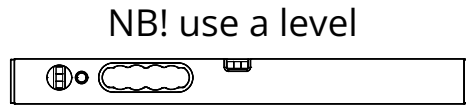

wood piece (cut it from removed connection strips)

S5	Screws 4,5x60 for Spruce Screws 4,2x55 for Thermo	120
		

**Please countersink the screw head(s)!**  
**Use a rubber mallet to tap the planks into place!**  
**Please do not screw the screws in on the last whole blanks immediately!**

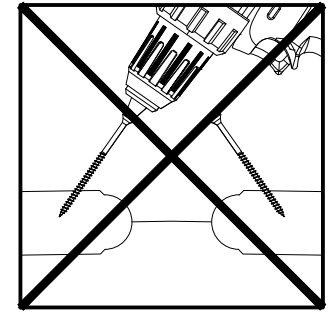

**B3a**  
 layout of labeled boards

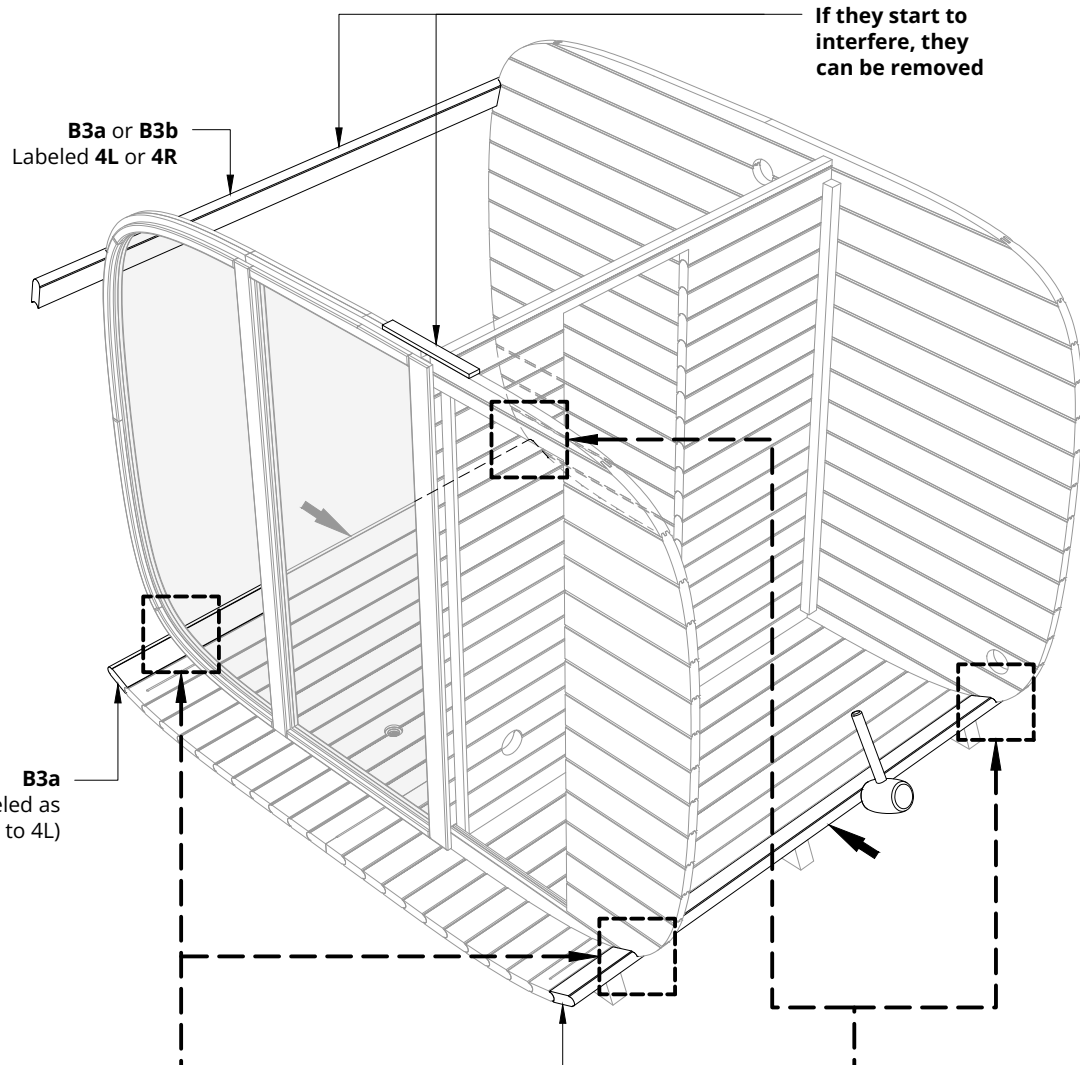
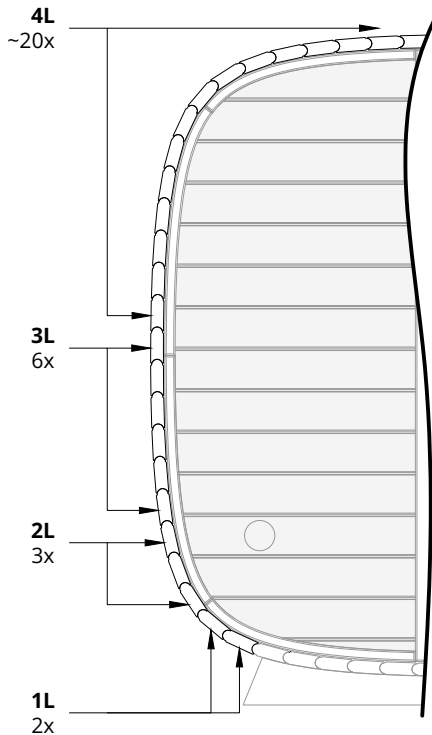

**B3b**  
 layout of labeled boards

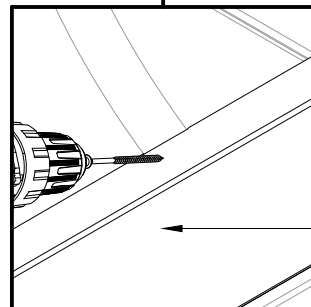
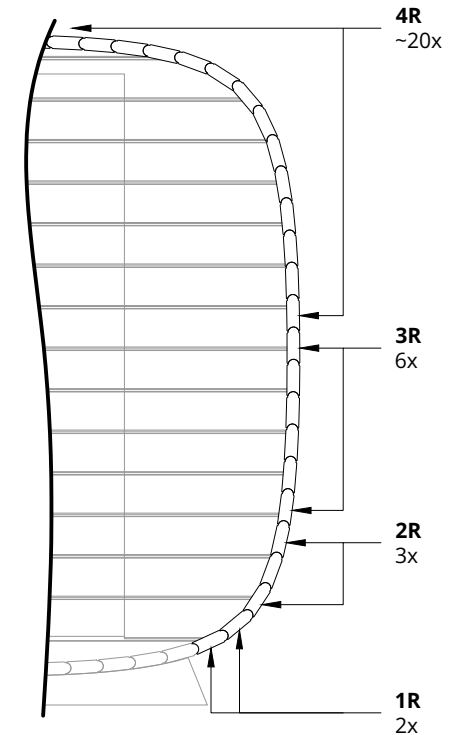

**B3b**  
 (Labeled as 1R to 4R)

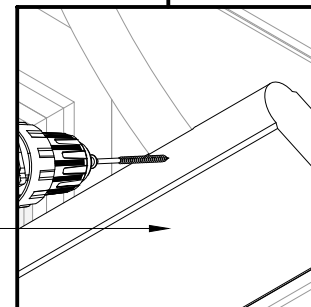

**B3a left**  
 (Labeled as 1L to 4L)  
**B3b right**  
 (Labeled as 1R to 4R)



**Measure the gap front and back,  
the dimensions can be different!**

Divide the measurement by two and transfer the measurements to the last two planks. Connect the dimensions on the plank with a line.

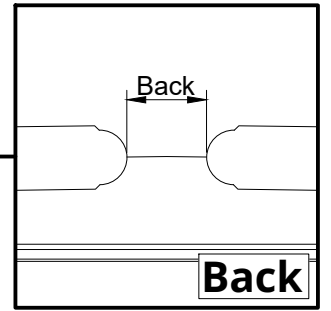
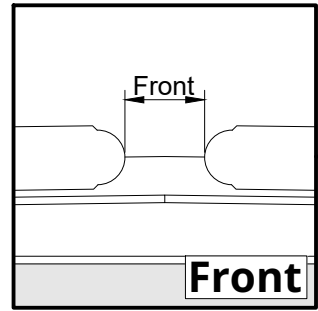
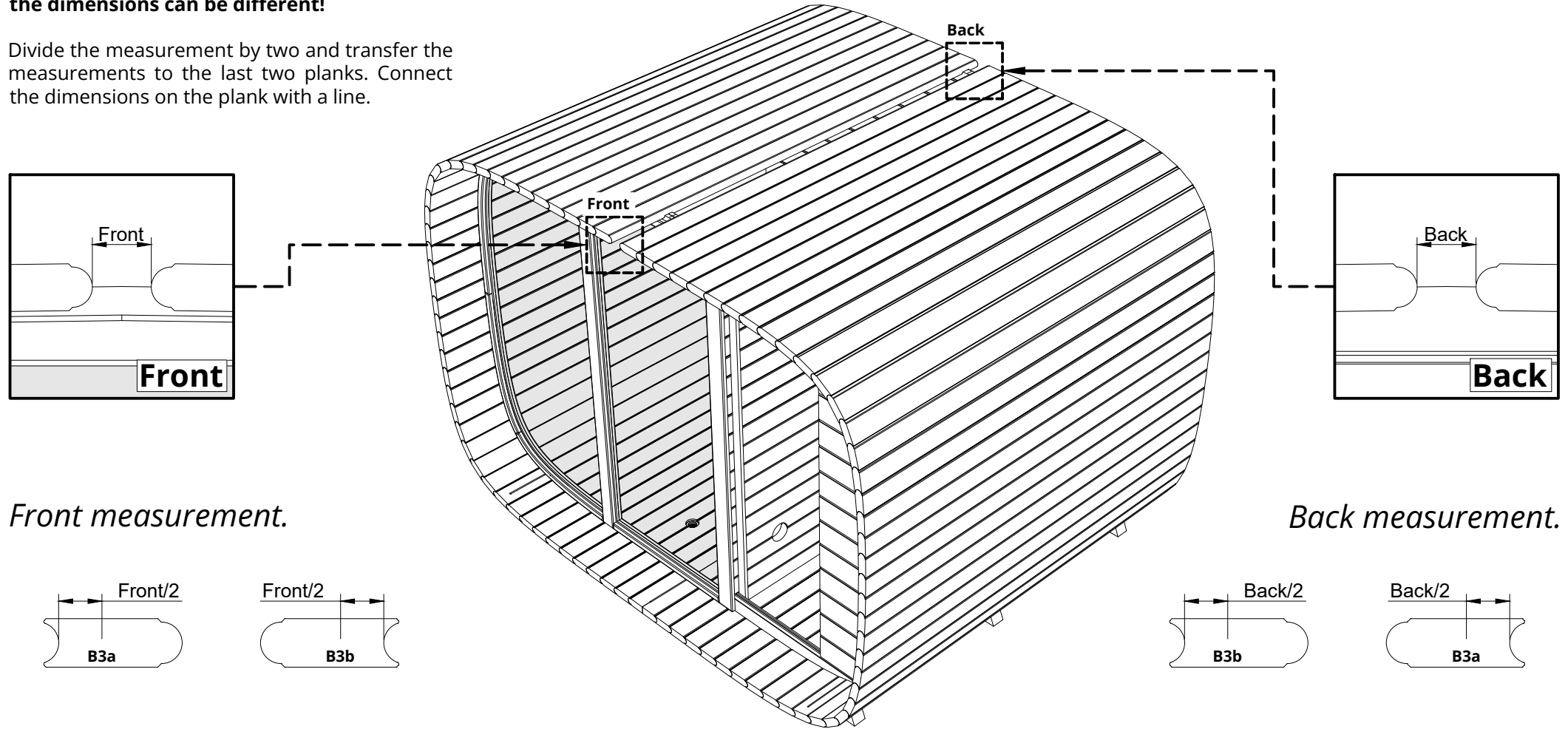

*Front measurement.*

*Back measurement.*

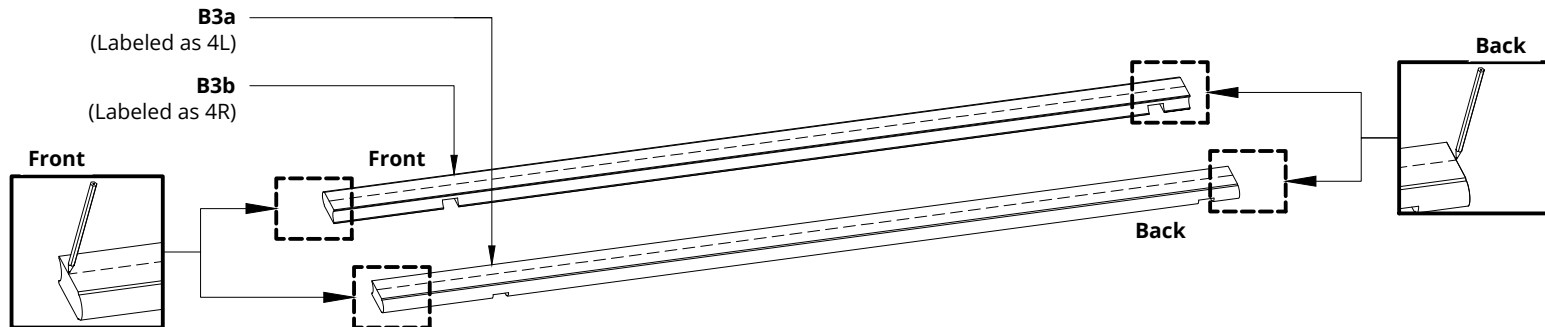
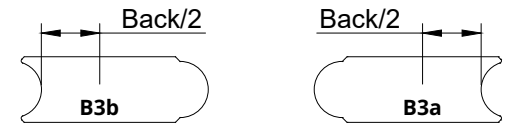
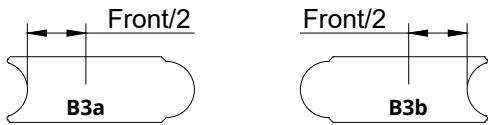

S2...7	Screws 3x40 ... 4,5x80	7
S5	Screws 4,5x60 for Spruce Screws 4,2x55 for Thermo	6
		

**Please countersink the screw head(s)!**  
**Prepare the last plank!**  
**Use a rubber mallet to tap the planks in to the cap!**

Cut along the marked line to cut off these ends. Glue the two cut boards with wood glue and connect them with 7 pieces of 3x40 ... 4.5x80 screws (the length of the screws depends on the final width of the last two planks cut). Wipe off excess glue with a cloth and then use sandpaper to smooth out the gap.

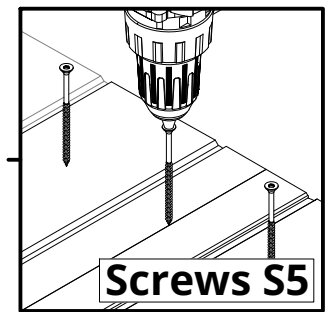
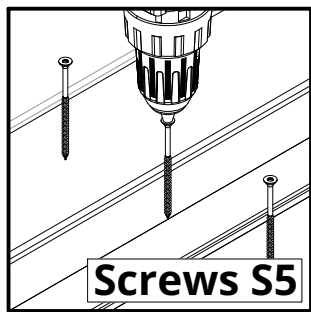
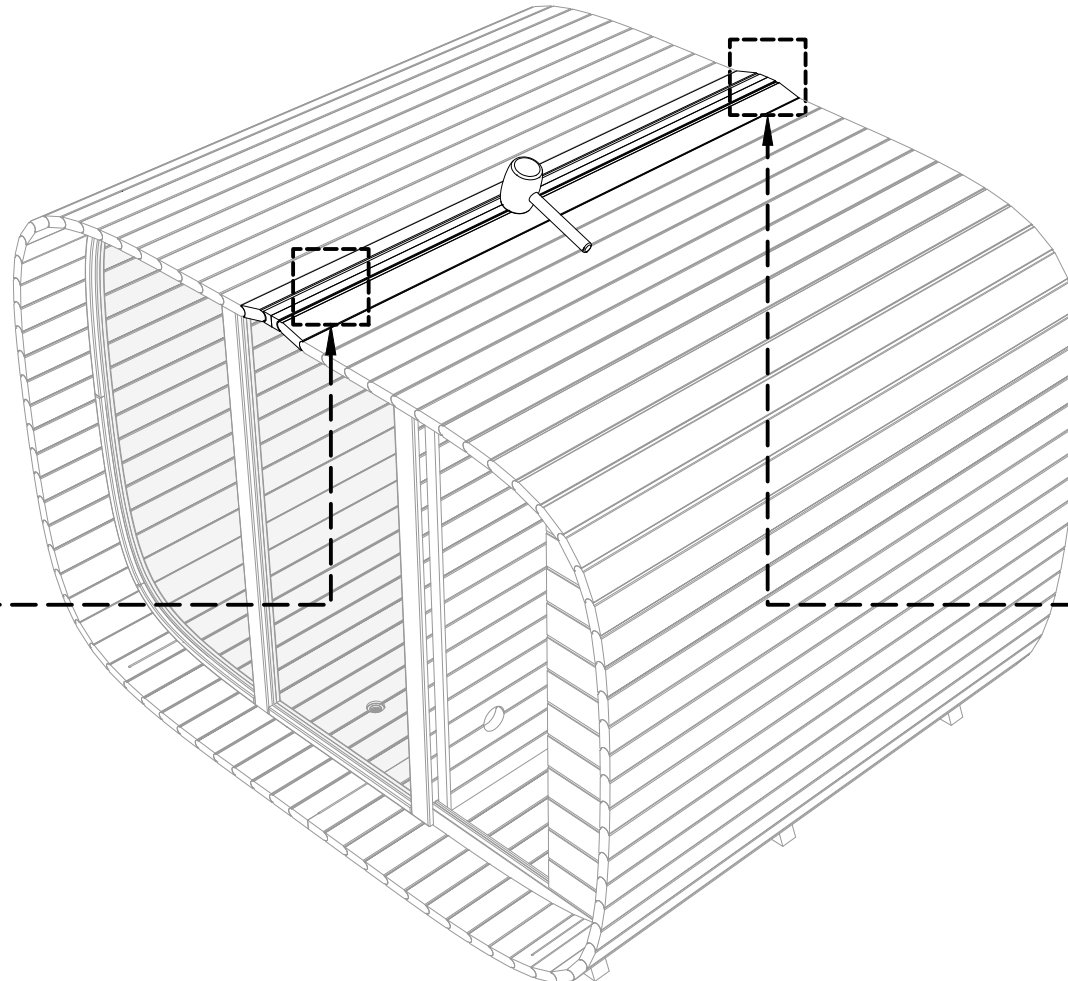
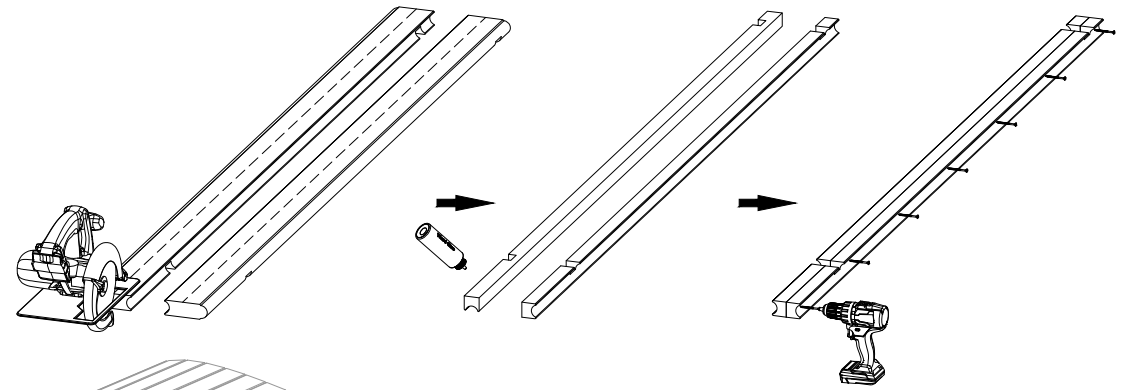

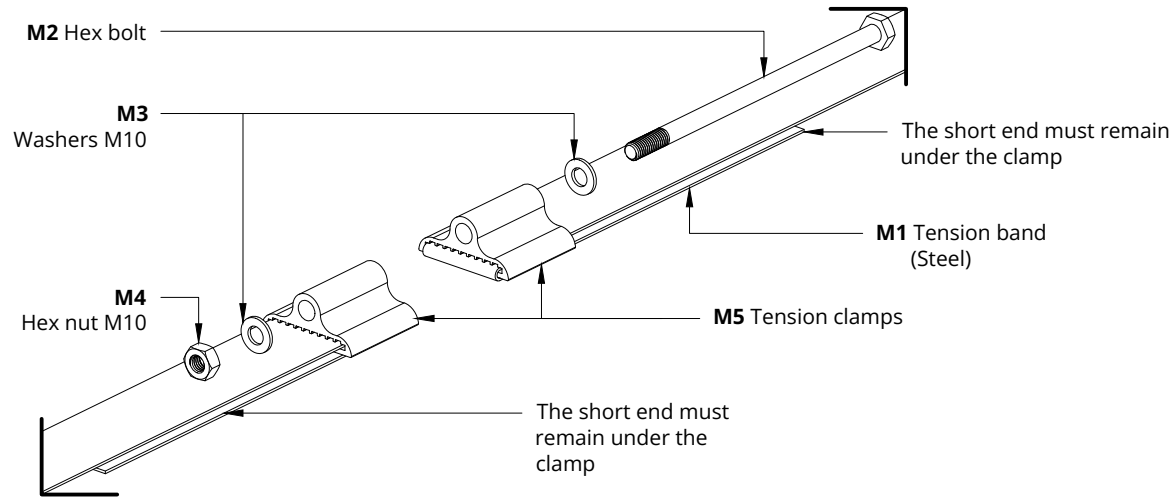



Place the tension bands M1 (Steel band) around the side walls and thread the bands into the eyelet as follows (see sketch above).

Hex nuts and bolts must be tightened as long as the planks are stationary in all directions.

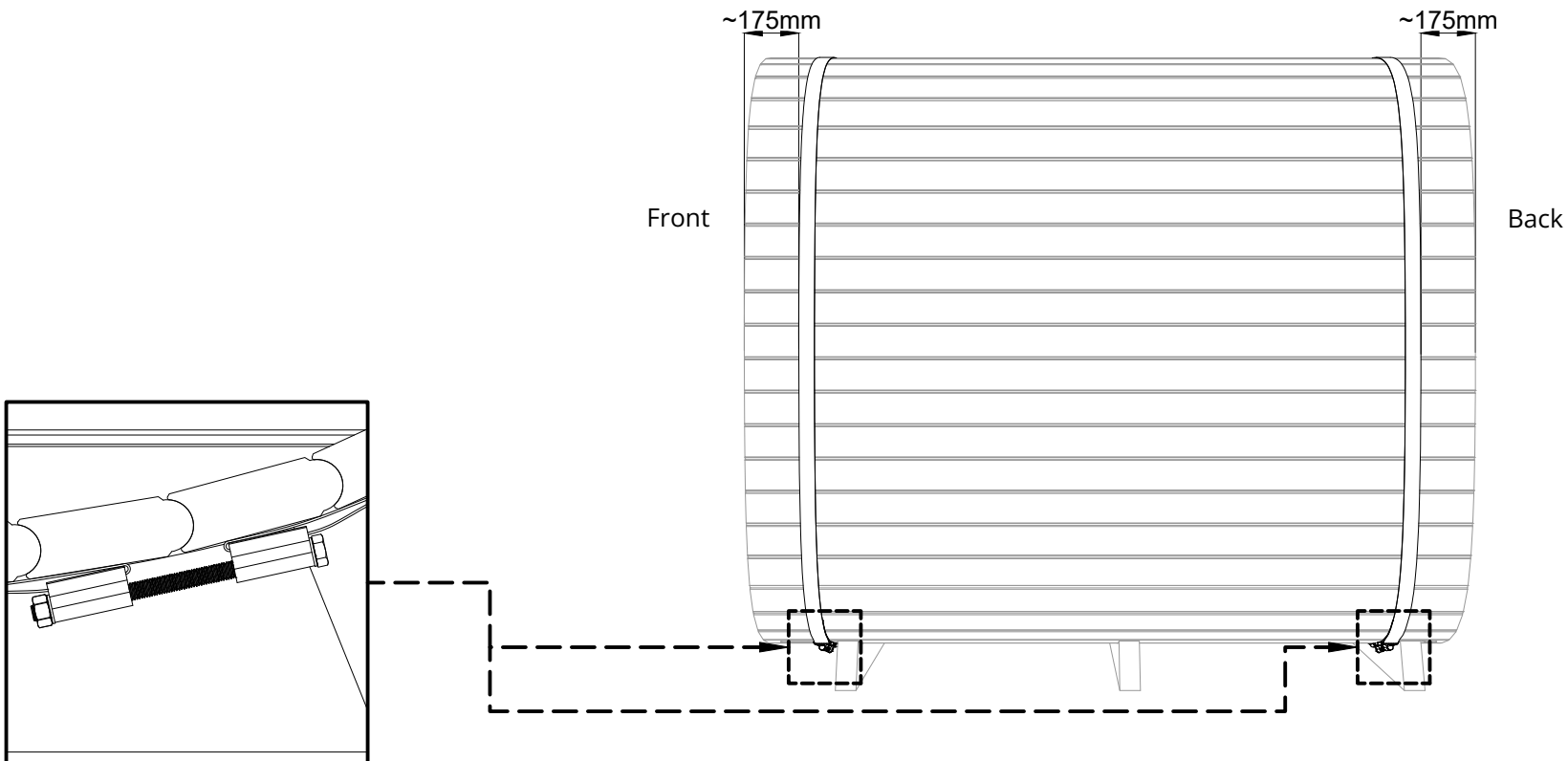
**The tension band and clamps must be placed as shown in the picture below.**



R6	Nail 2,5x25	~26
		

Install the outer underlay's first and fasten with nails!  
 Install the middle underlay!  
 Use the heat source on the middle underlay, along the long edges for better adhesion!  
 Cut off the ends that extend over the edge!

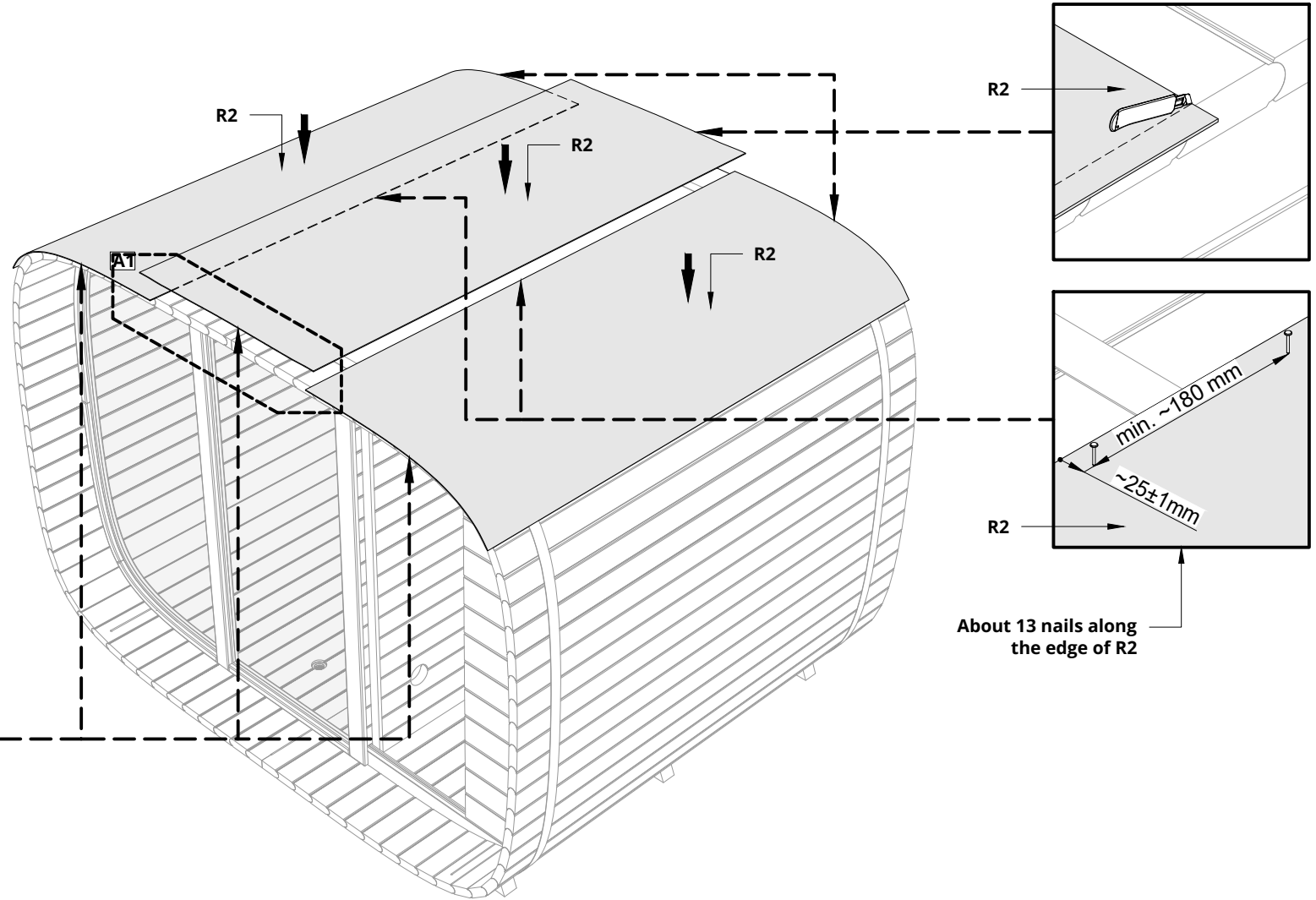

About 13 nails along the edge of R2

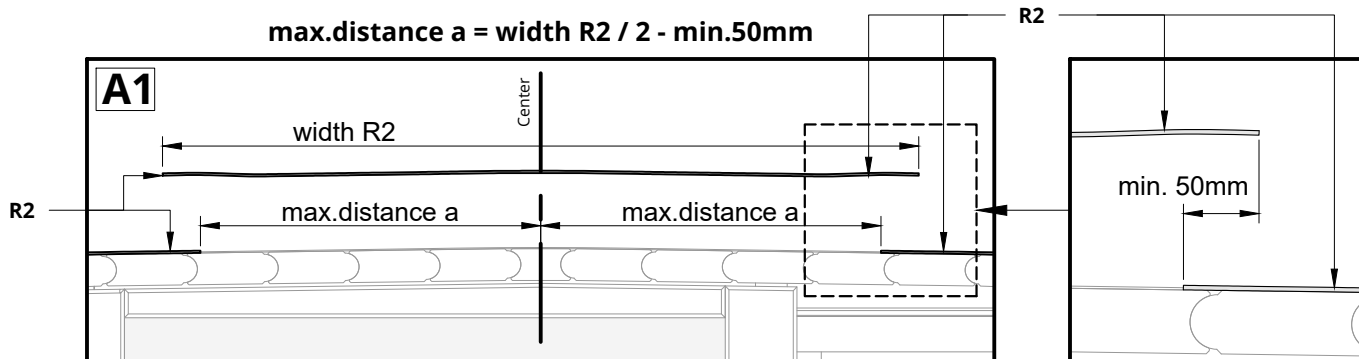
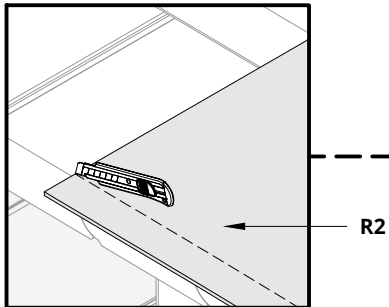

**Cover underlay joints with adhesive tape, on top of the sauna!**  
**Cover the edge of the underlay, at the front end of the sauna and at the back of the sauna, with adhesive tape!**  
**Front and back end, fold the adhesive tape over the edge!**

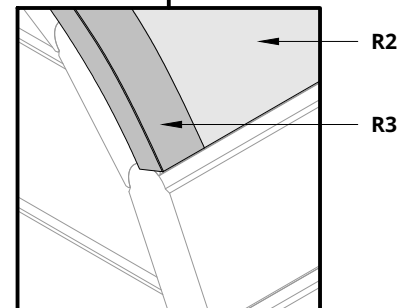
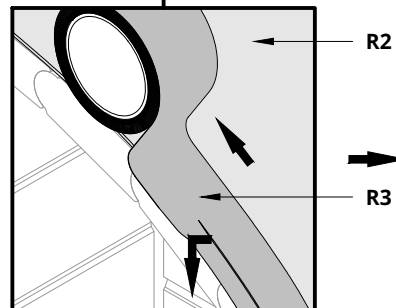
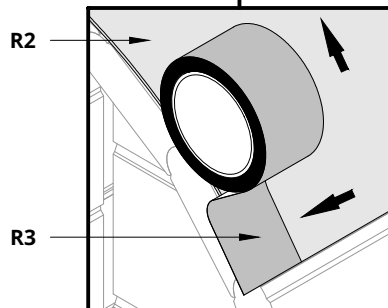
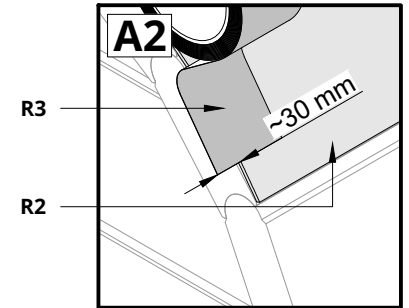
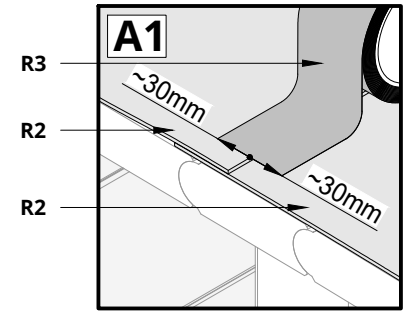
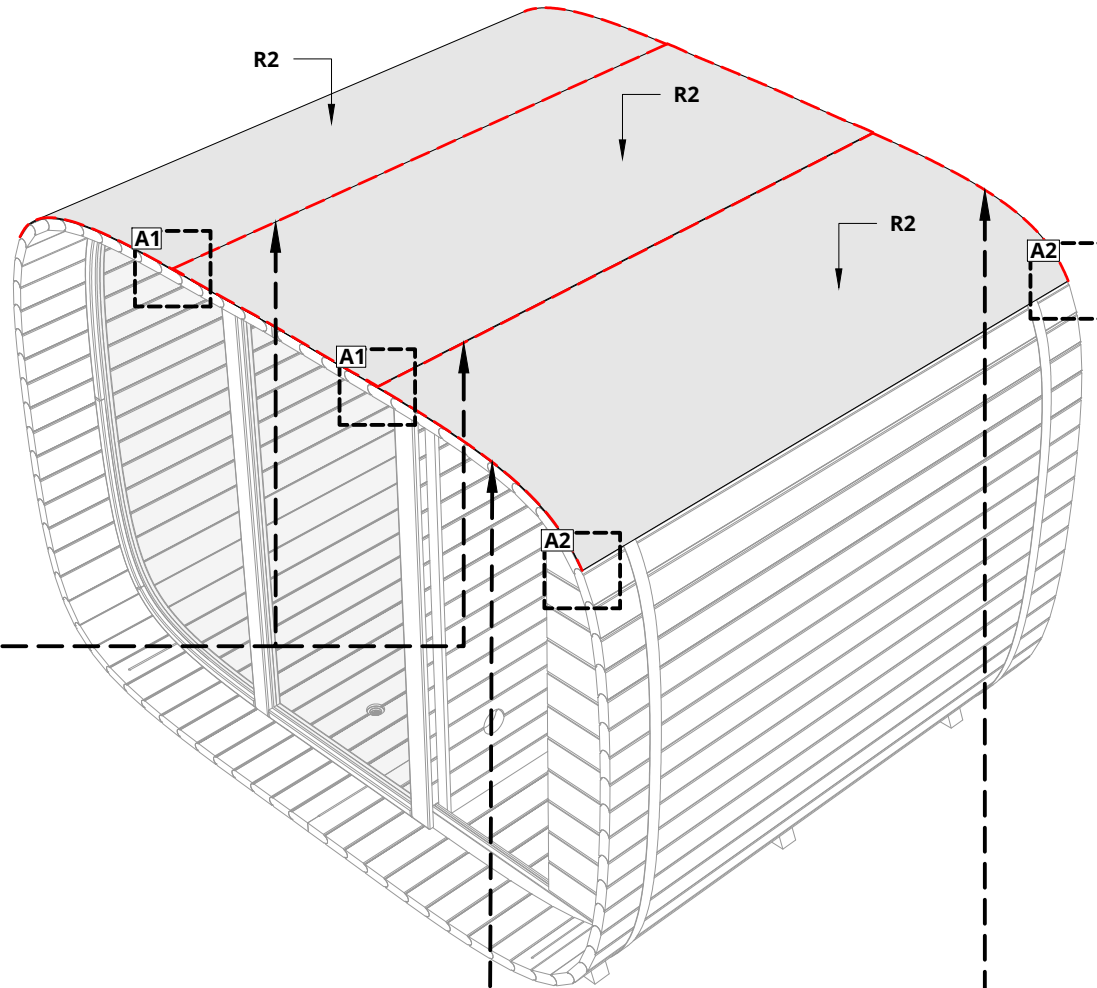
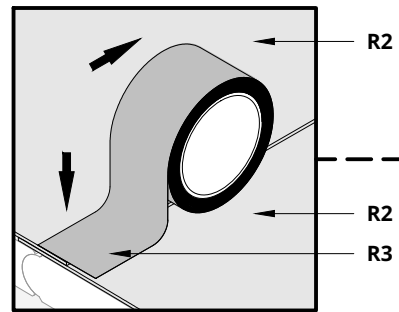

R6	Nail 2,5x25	~44
		

Sheets are self-adhesive, for better adhesion use a heat source!

The base row starts from the front, from the second board and with offset!

Cut sheets that extend over the edge!

Suitable leftovers can be used!

Repeat these steps on the other side as well!

Recommendation for proper installation are in separate pages.

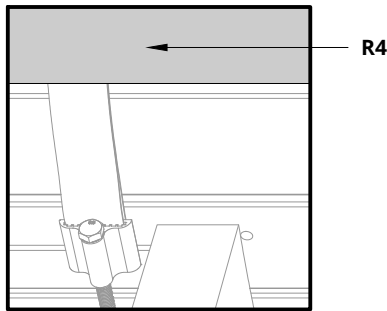
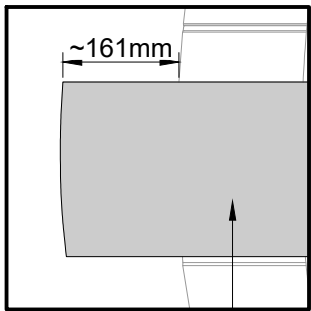

R4

R4

Base row

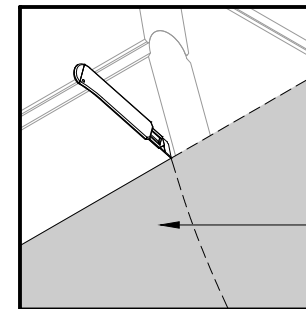
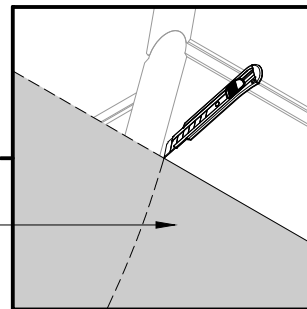
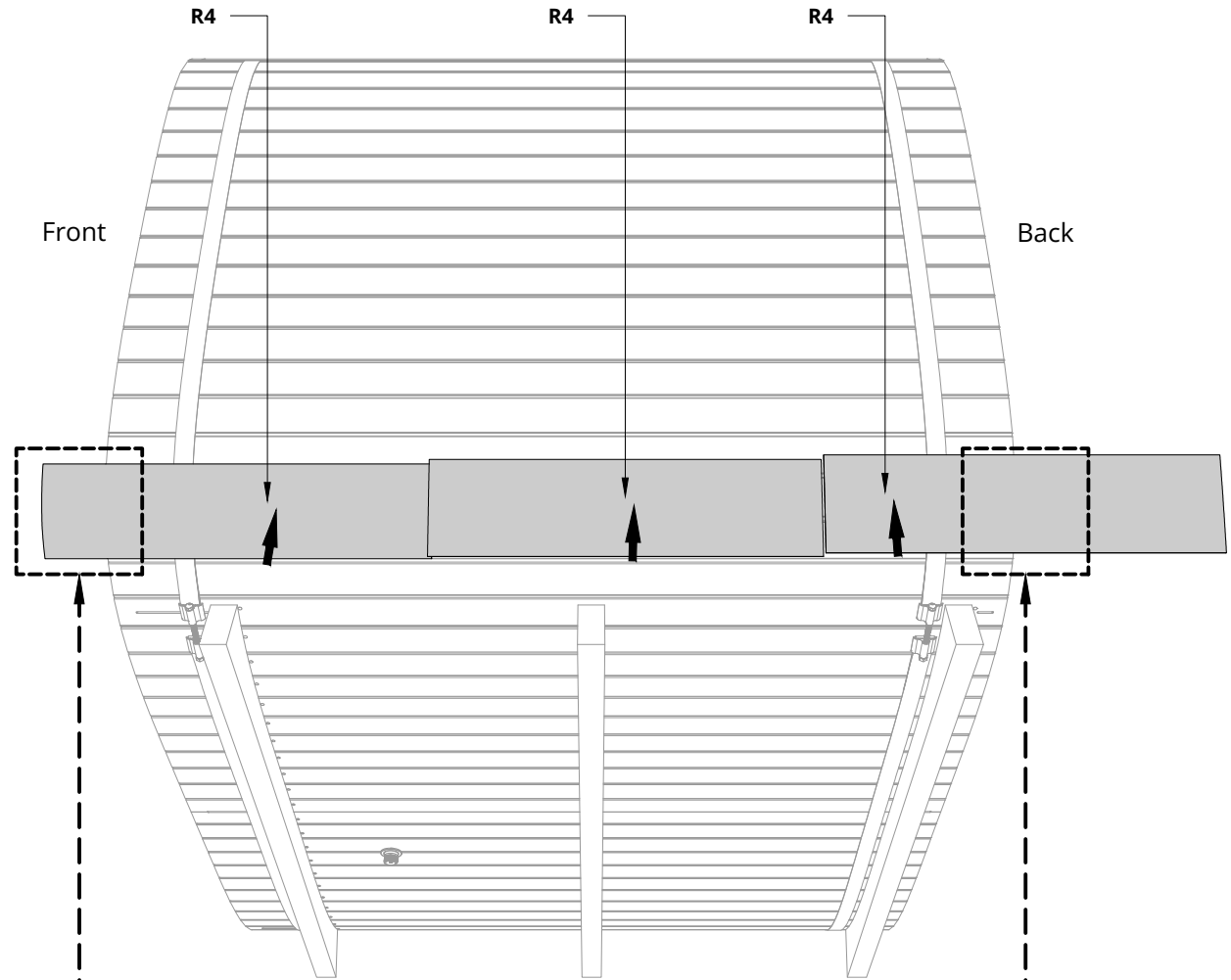
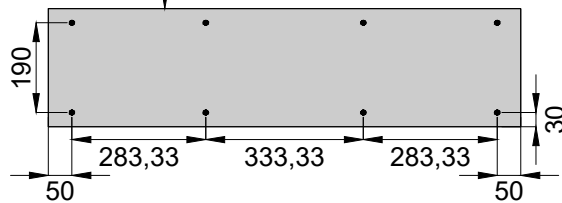

R6	Nail 2,5x25	~326
		

Sheets are self-adhesive, for better adhesion use a heat source!  
 The 1. row starts from the bottom and center of the side wall of the sauna.  
 Cut sheets that extend over the edge!  
 Suitable leftovers can be used!  
 Repeat these steps on the other side as well!

Recommendation for proper installation are in separate pages.

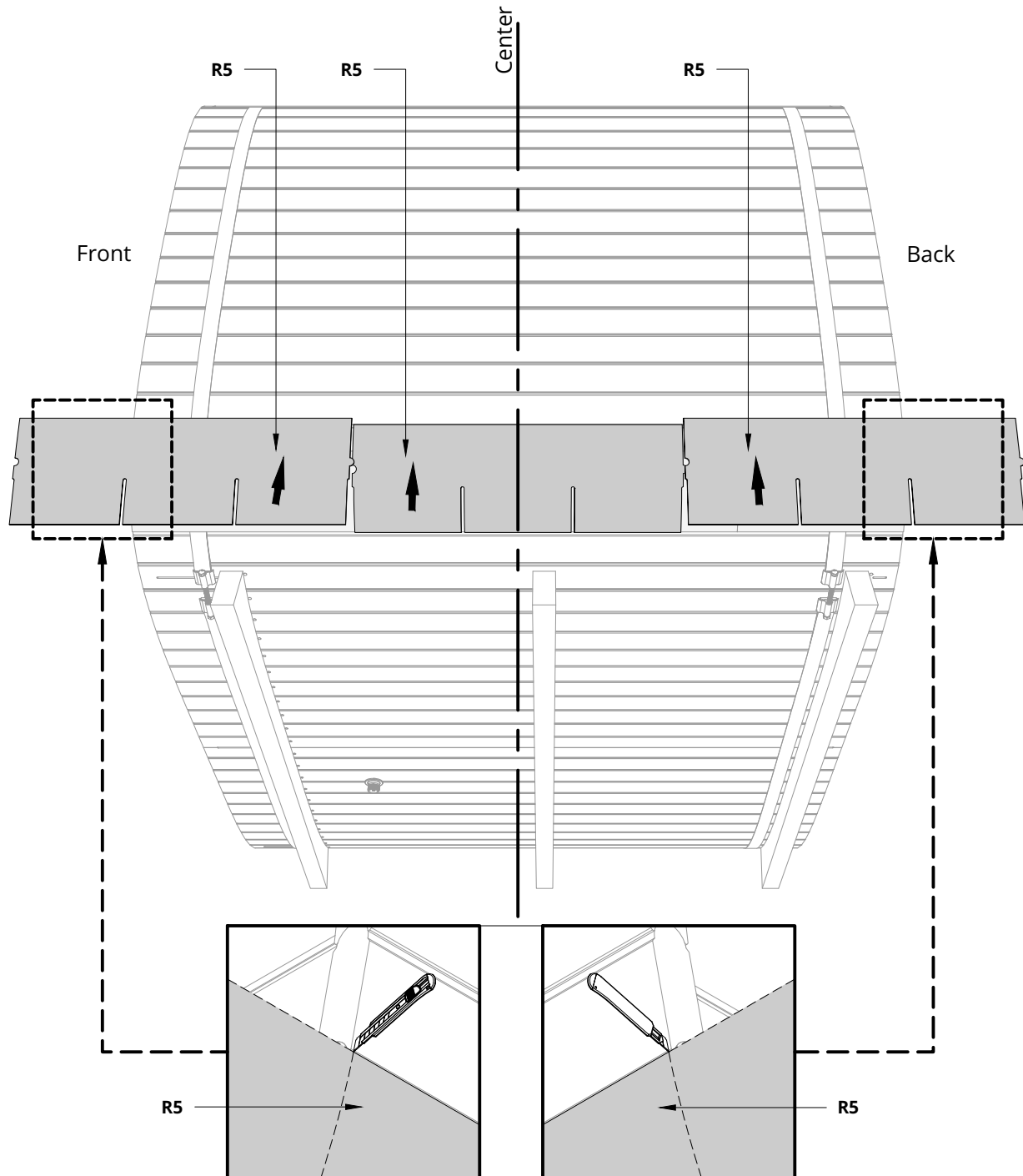
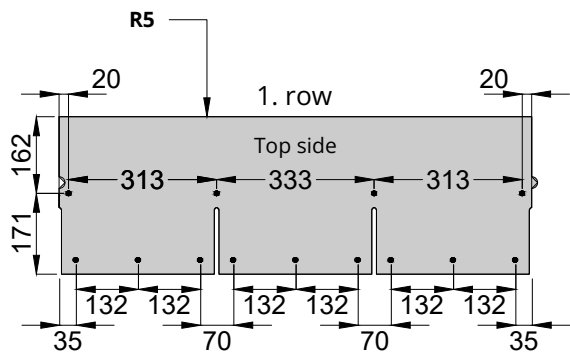
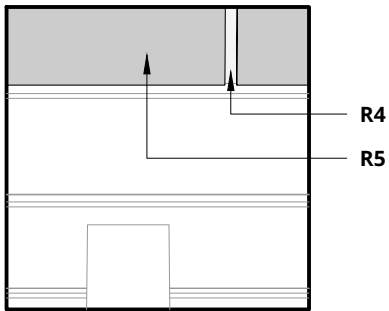

R6	Nail 2,5x25	~52
		

Sheets are self-adhesive, for better adhesion use a heat source!  
 The roof ridge can be started from the back end of the sauna or from the front end!  
 Cut sheets that extend over the edge!

Recommendation for proper installation are in separate pages.

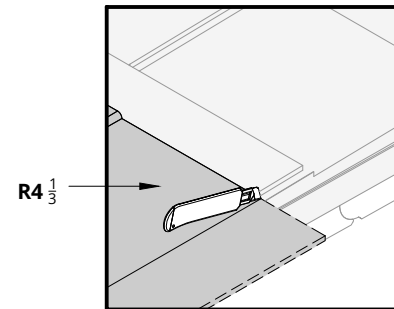
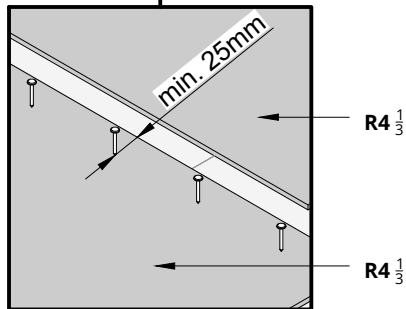
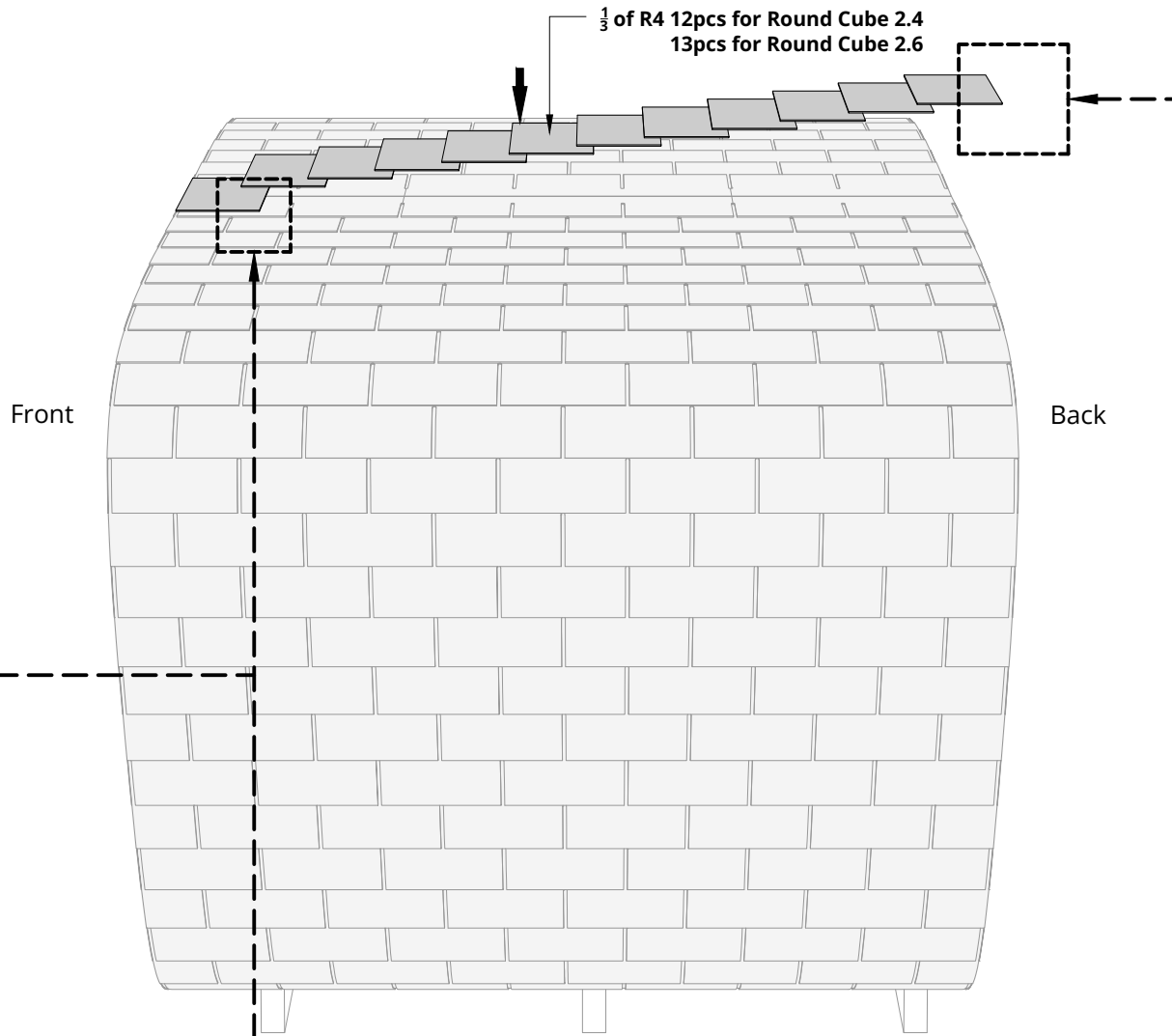
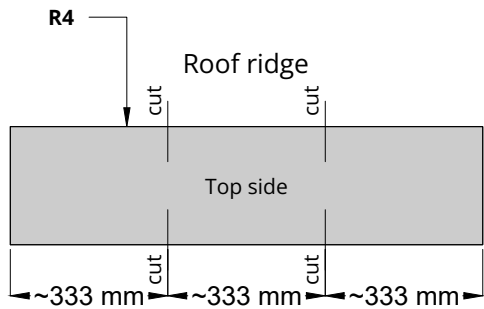
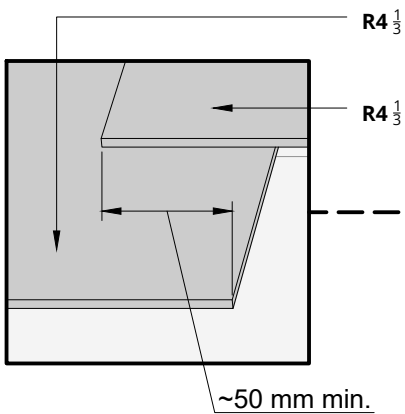



S6.1	Screws 4,5x70 (Black coated)	60

**Please countersink the screw head(s)!**  
**Install the cover boards with 3 screws!**  
**Add glue for the 3 lower cover boards!**  
**Fill the gaps between the bitumen sheets and covering boards in front and back!**

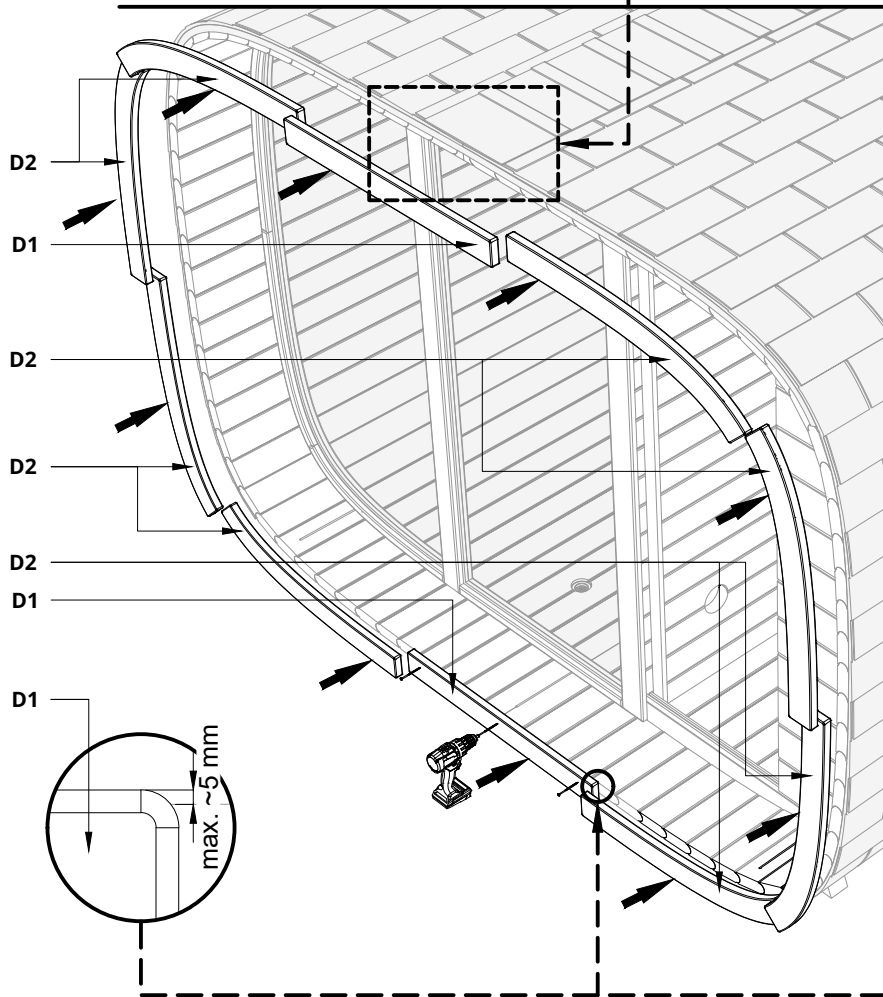
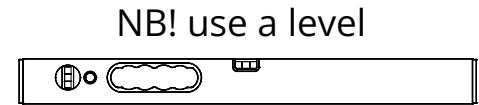
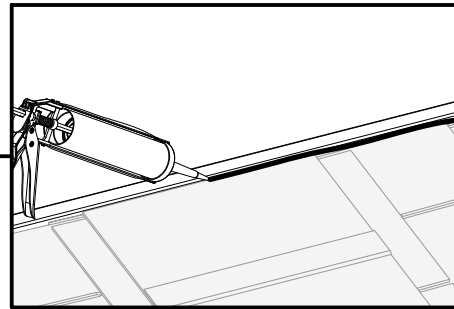

Frontside of Round Cube (DOUBLE)

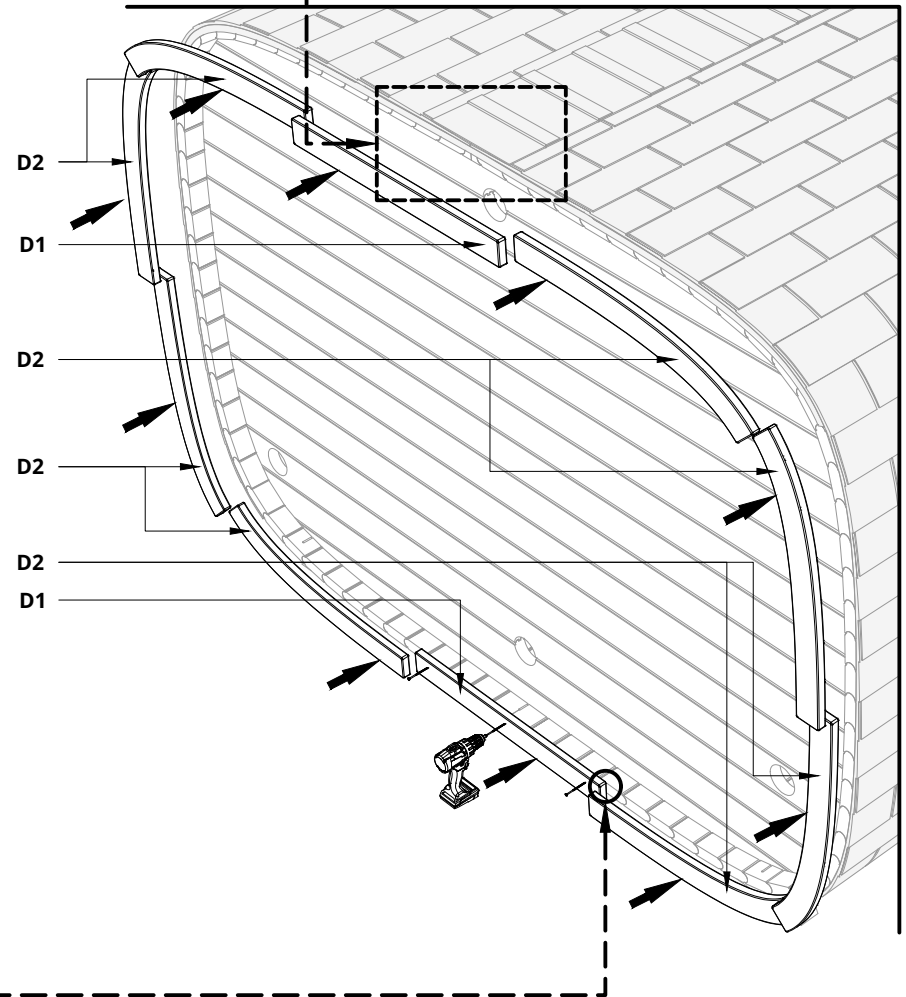

Backside of Round Cube (DOUBLE)

S1	Screws 3x30	30
		

The inner and outer ventilation grilles V2 and adjustable cover V3 are screwed with 3 screws.

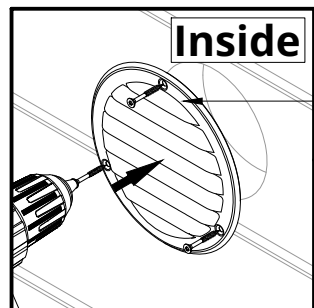
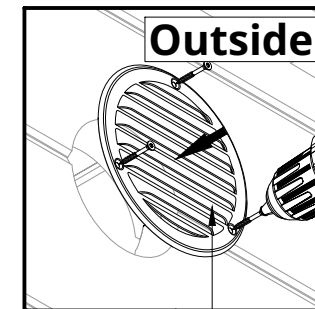
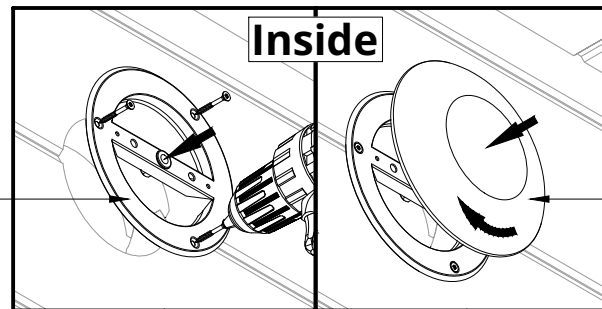
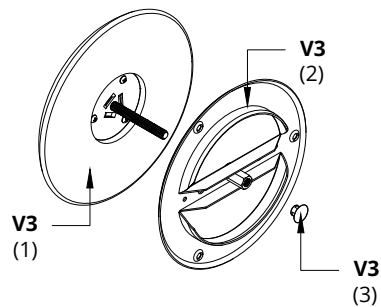

V2 (Brown)

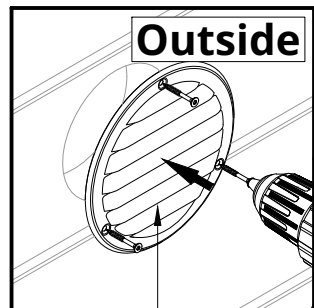

V2 (Black)

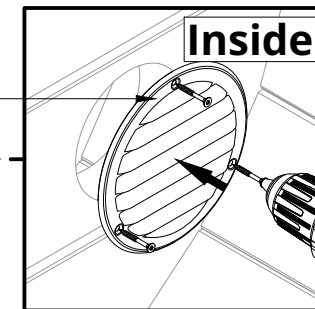
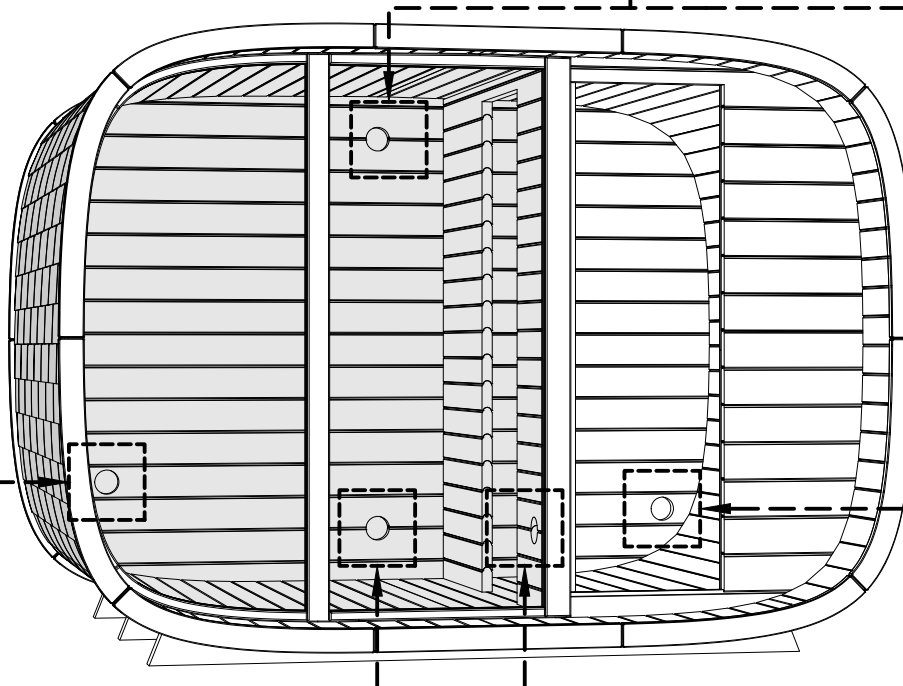

V2 (Brown)

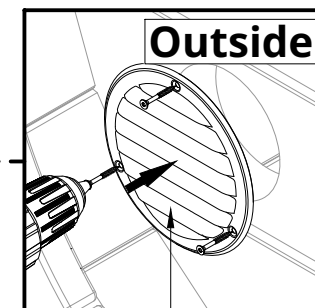

V2 (Black)

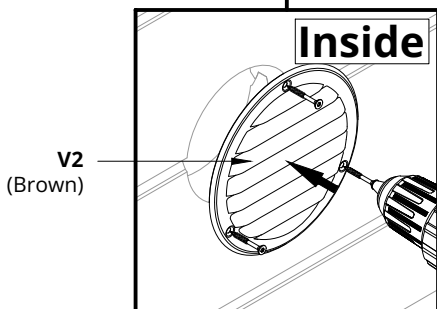

V2 (Brown)

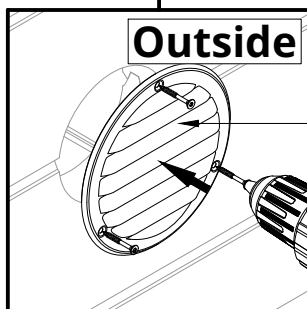

V2 (Black)

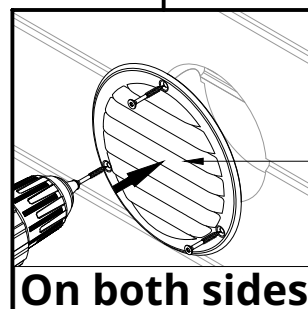



V2 (Brown)

N1	Lath nail	30
		

Cut the cover moldings to the correct size!

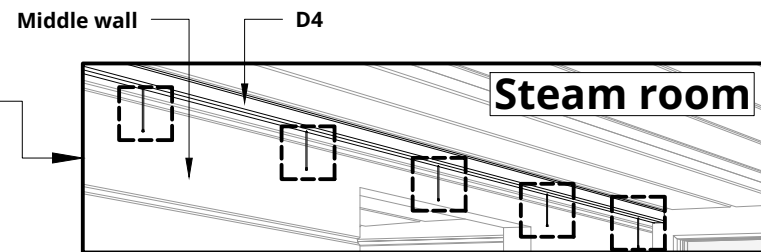
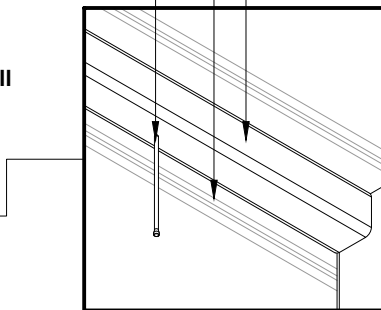
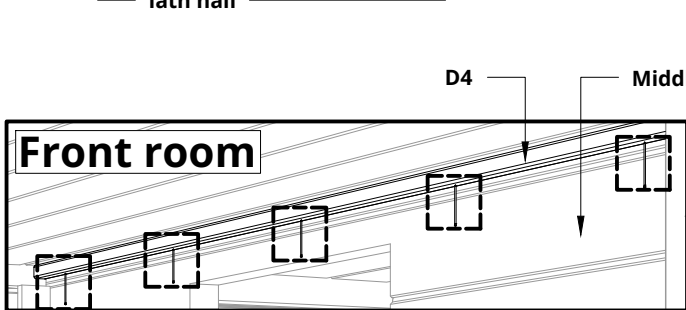
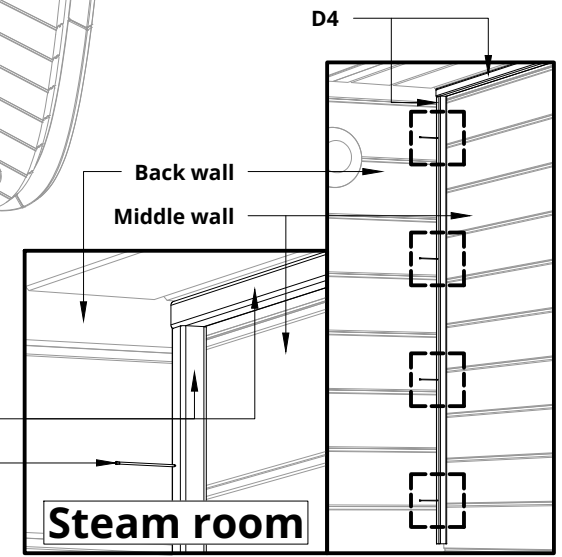
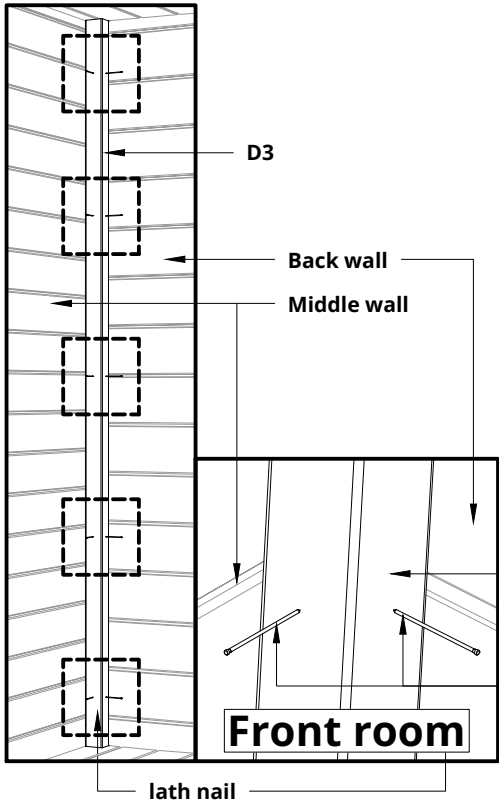
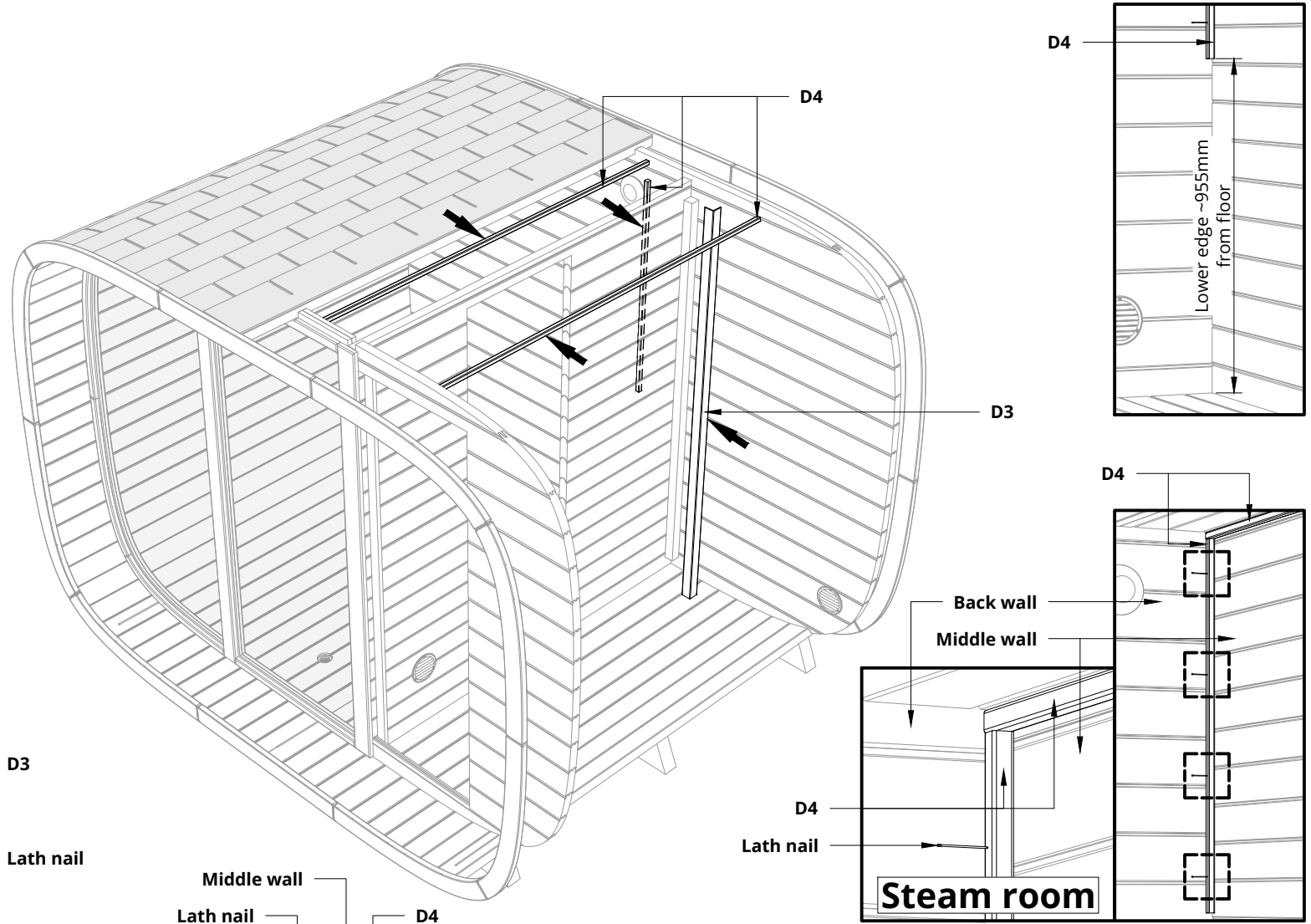
Install the cover strips!



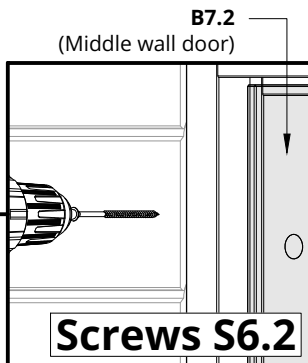
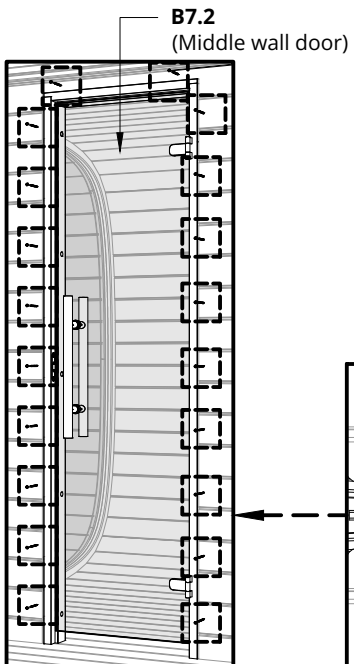
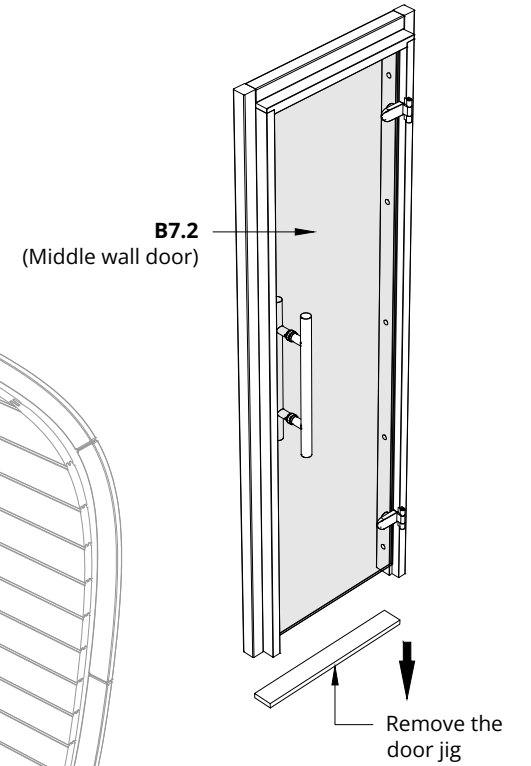
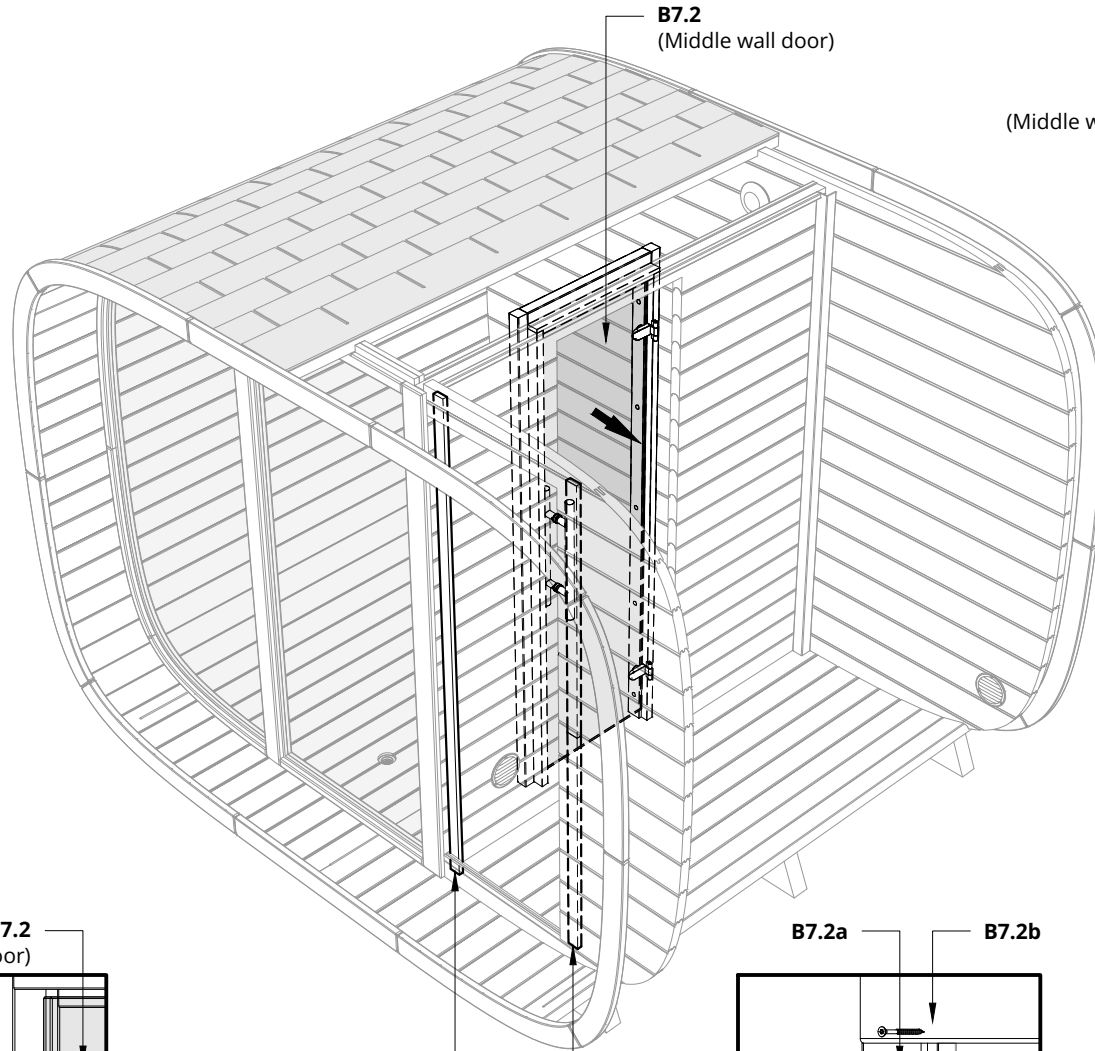
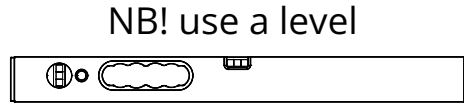

S6.2	Screws 4,2x75	20
S2	Screws 3x40	13
		

**Please countersink the screw head(s)!**  
**Remove the jig from the door!**  
**Install the door from the inside, fasten with screws and install door moldings!**  
**Remove the connecting strips from the front wall!**

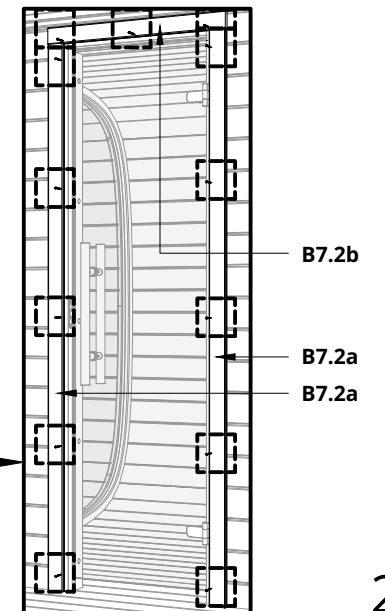
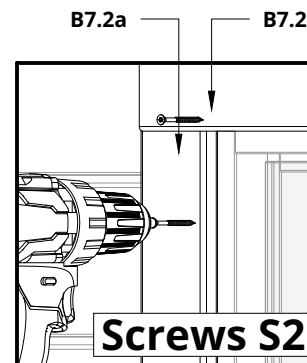

Remove the front wall connection strips



S6.2	Screws 4,2x75	16
S3.2	Screws 4,5x50 (Nano coating)	9
		

**Please countersink the screw head(s)!**  
**Remove hole covers if they are attached!**  
**Install the door from the inside, fasten with screws and install door moldings!**

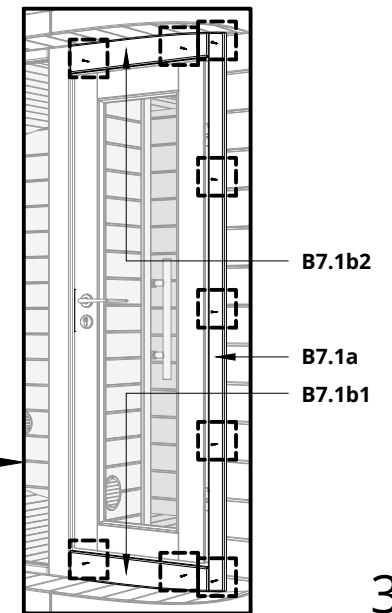
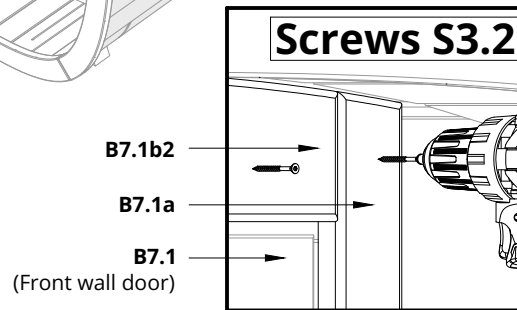
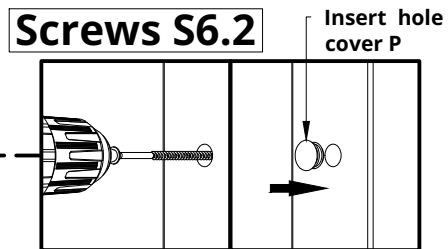
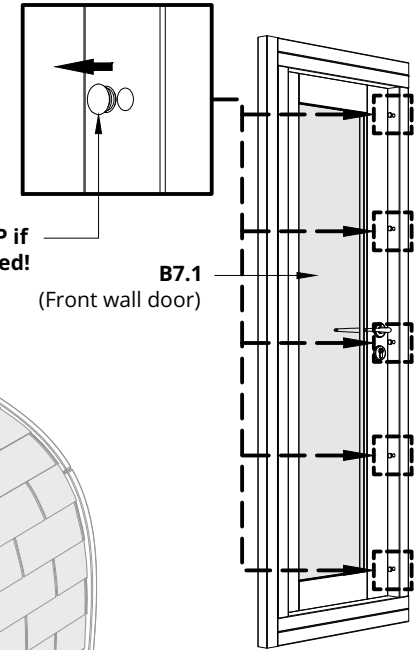
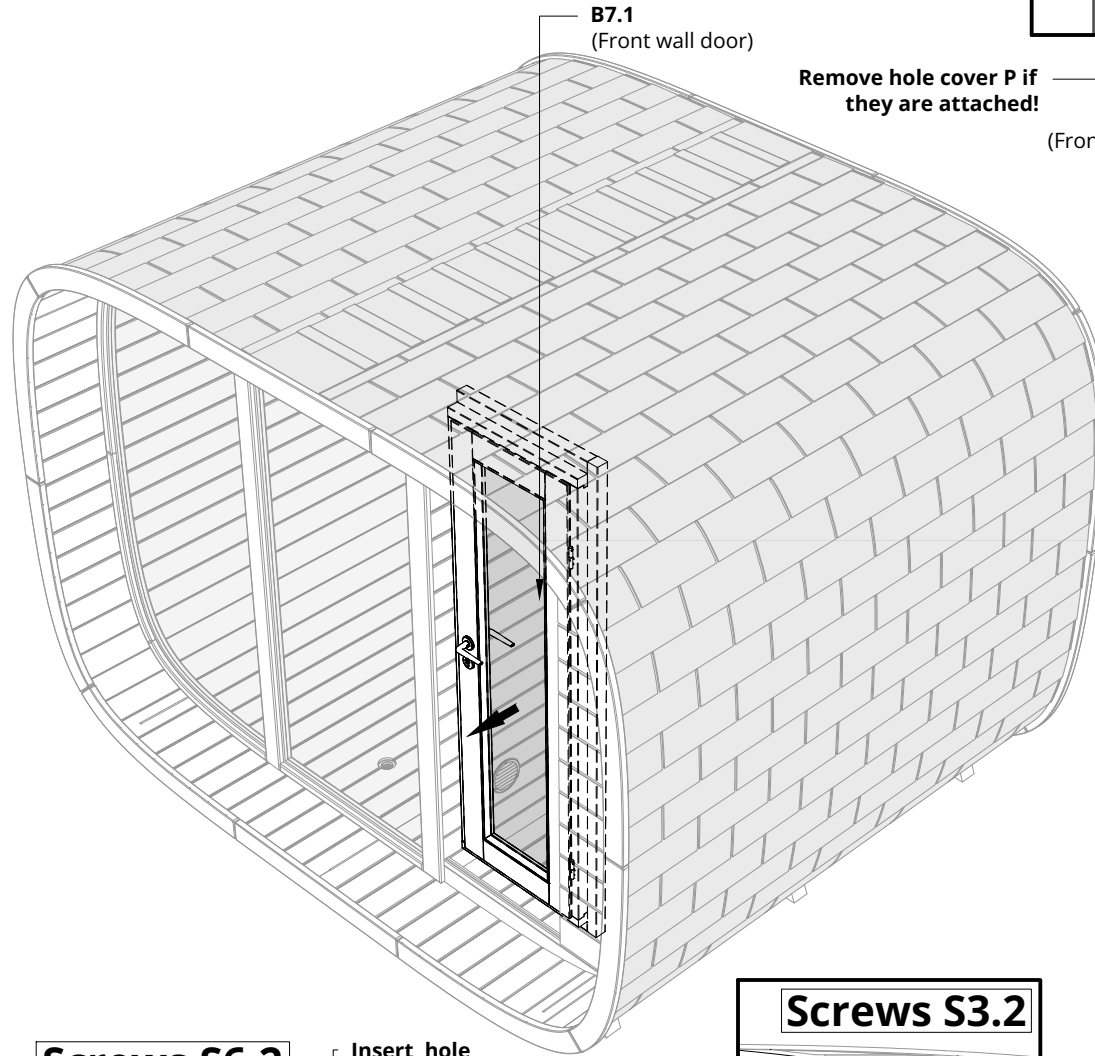
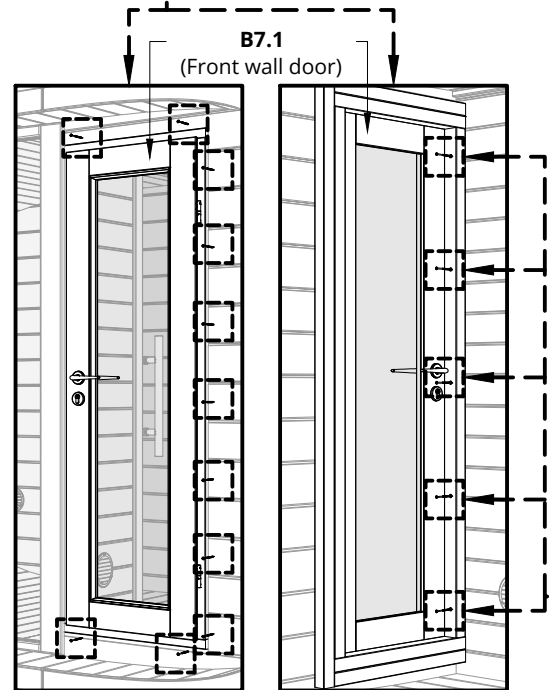
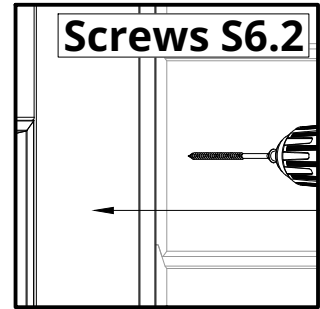
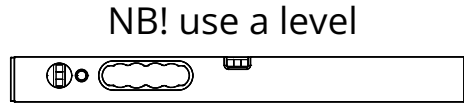

# Round Cube

## Bench assembly guide

Round Cube (DOUBLE 2.4 and 2.6)

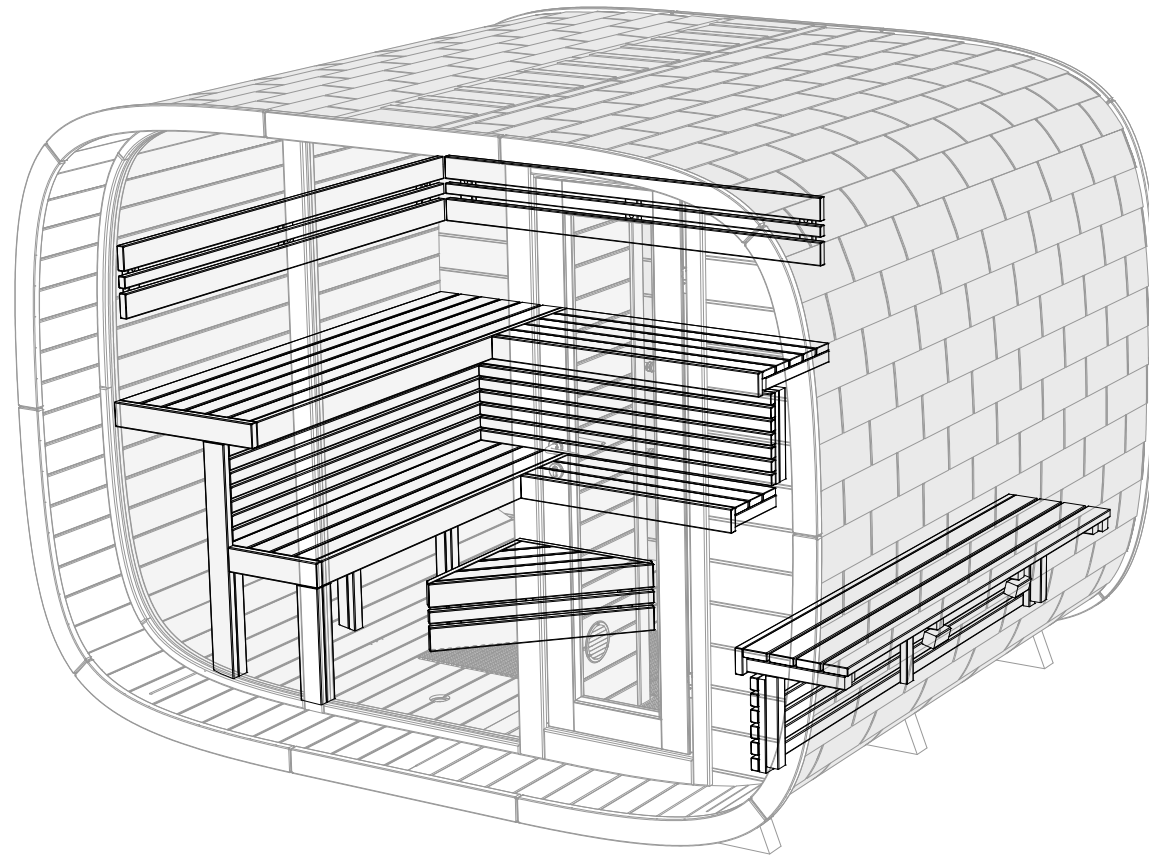

*Read the manual and check the parts for completeness before assembly!*



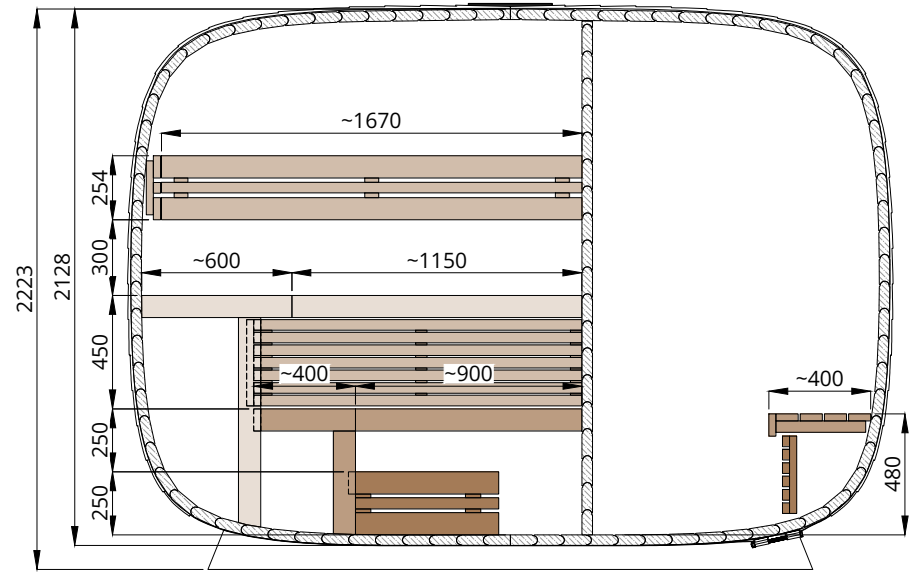
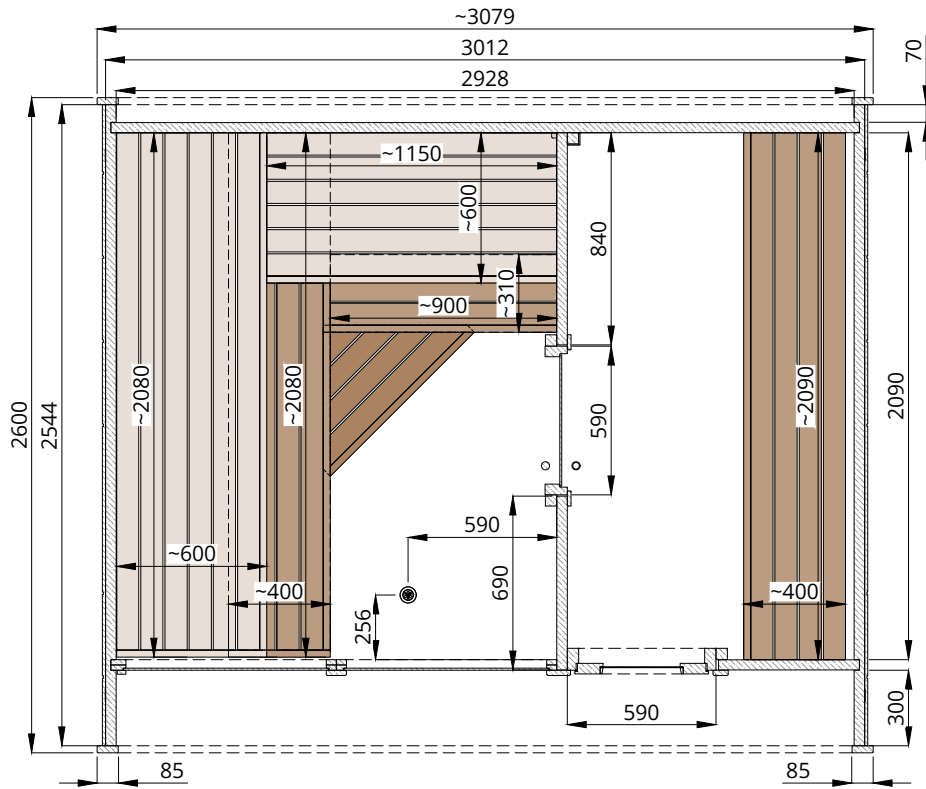

# Round Cube

(DOUBLE) 2.6



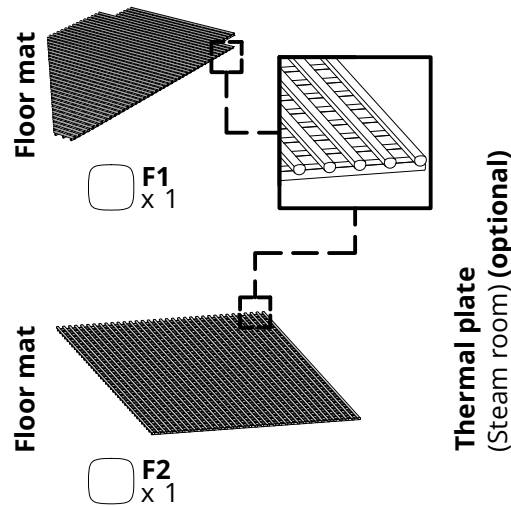
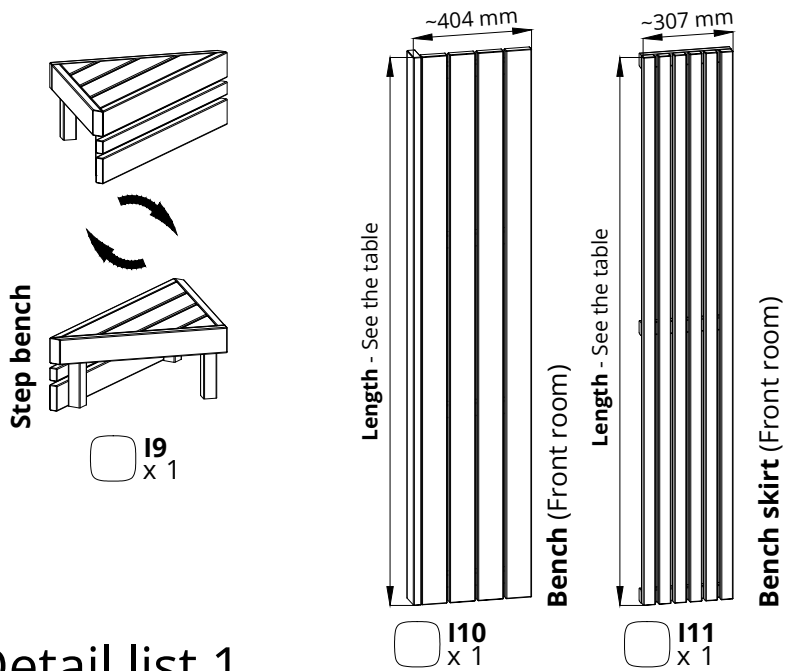
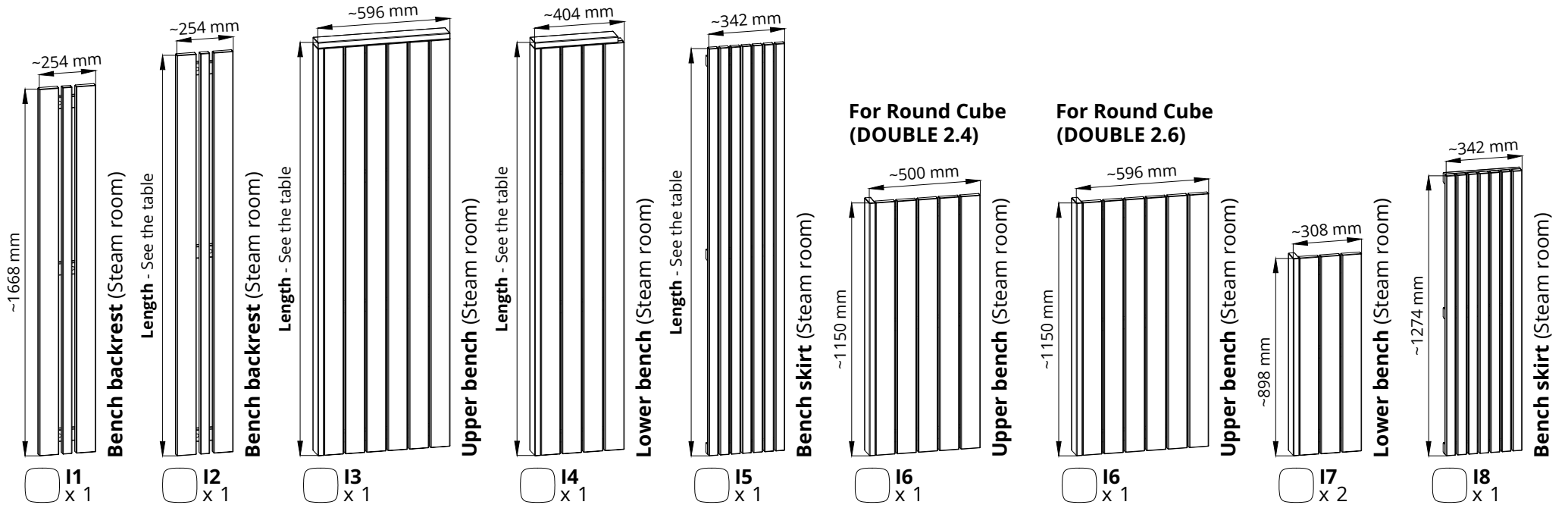

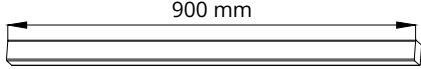
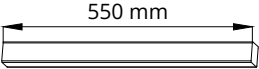
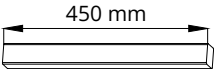
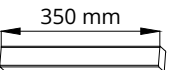
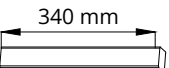
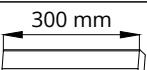
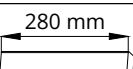
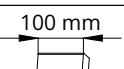

Round Cube (DOUBLE)		
Length	2.4	2.6
I2	~1822 mm	~2022 mm
I3	~1880 mm	~2080 mm
I4	~1880 mm	~2080 mm
I5	~1852 mm	~2052 mm
I10	~1890 mm	~2090 mm
I11	~1890 mm	~2090 mm

# Detail list 1

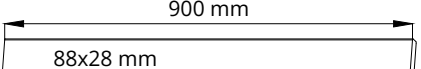
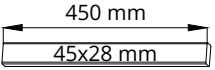
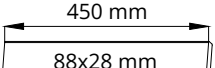
Round Cube		DOUBLE 2.4	DOUBLE 2.6	
Name in manual	K Square woods 45x45mm			
K90		1		<input type="checkbox"/>
K55		1	3	<input type="checkbox"/>
K45		5	3	<input type="checkbox"/>
K35		3		<input type="checkbox"/>
K34		3		<input type="checkbox"/>
K30		3		<input type="checkbox"/>
K28		2		<input type="checkbox"/>
K10		5		<input type="checkbox"/>

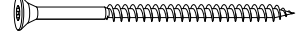
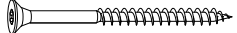
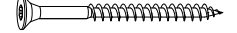
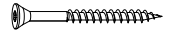
Round Cube		DOUBLE 2.4 and 2.6	
Name in manual	Cover boards		
D5		1	<input type="checkbox"/>
D6		4	<input type="checkbox"/>
D7		1	<input type="checkbox"/>
Name in manual	Screws (Scale 1:2)/ Screw size	Qty.	
S7	 Screws 4,5x80 for Spruce	50	<input type="checkbox"/>
	 Screws 4,2x75 for Thermo		
S5	 Screws 4,5x60 for Spruce	50	<input type="checkbox"/>
	 Screws 4,2x55 for Thermo		
S2	 Screws 3x40	5	<input type="checkbox"/>

## Detail list 2

S2	Screws 3x40	3
S5	Screws 4,5x60 for Spruce Screws 4,2x55 for Thermo	6
S7	Screws 4,5x80 for Spruce Screws 4,2x75 for Thermo	6



1. Remove hole cover P if they are attached!
2. Screw the bench backrest
3. Put the hole cover P back

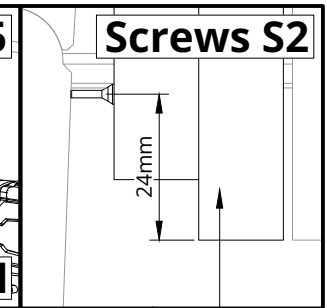
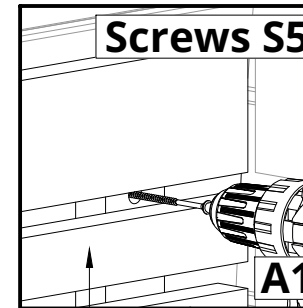
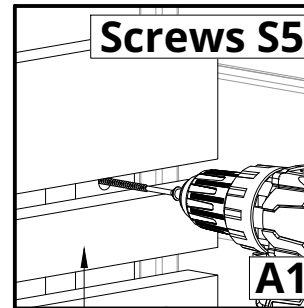
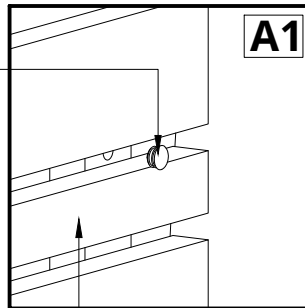

NB! use a level

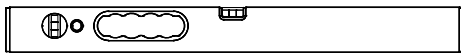

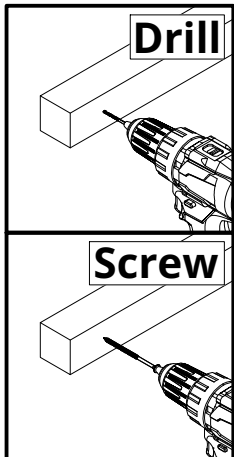
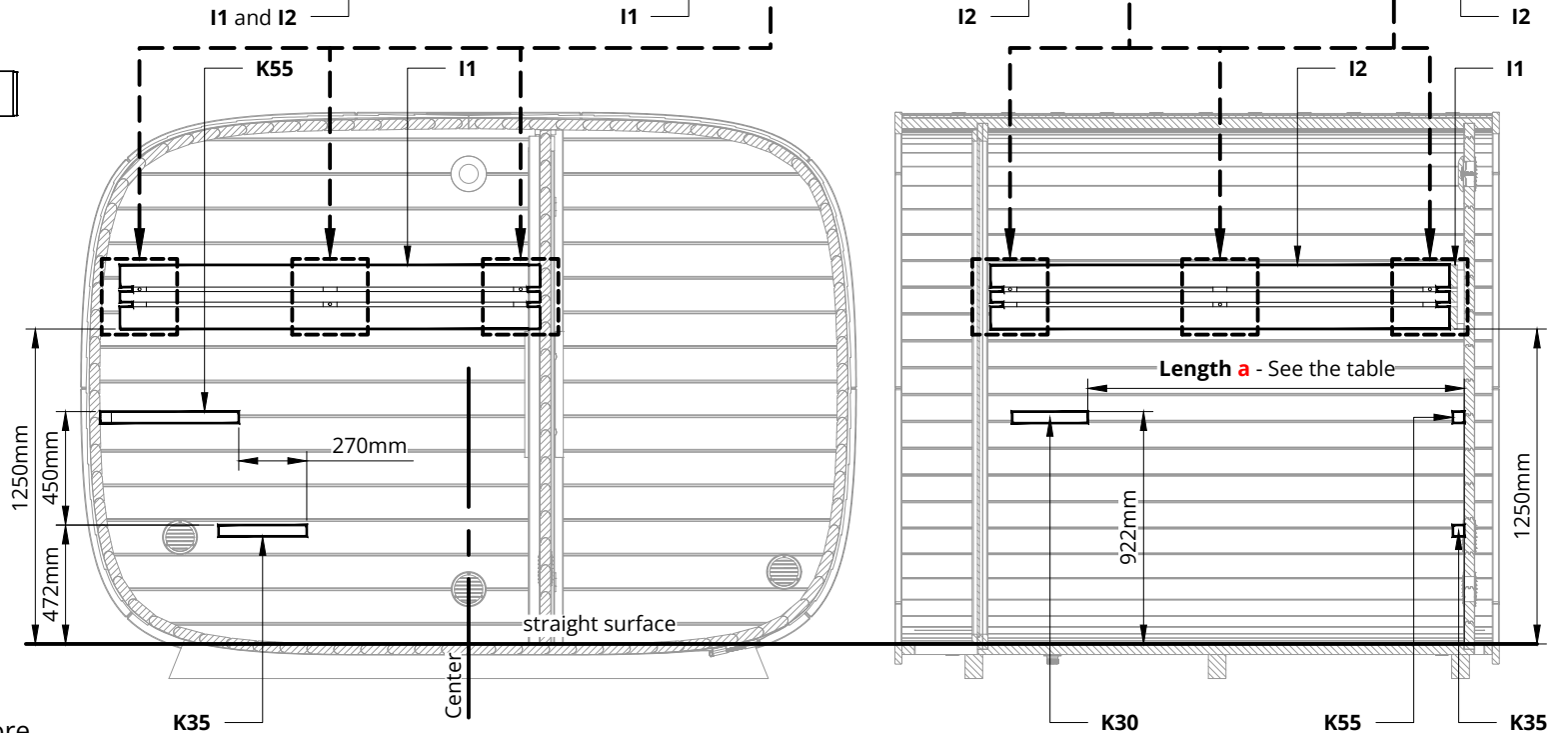

**Please countersink the screw head(s)!  
Height measurements are measured from a straight surface!  
Install the bench backrests I1 and I2!  
Install square woods for benches!  
Use glue between the square wood and the wall!**

Round Cube (DOUBLE)		
Length	2.4	2.6
a	~1495 mm	~1695 mm

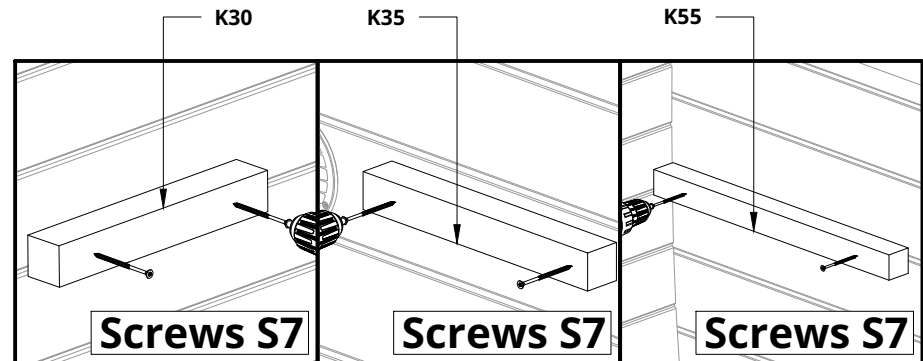
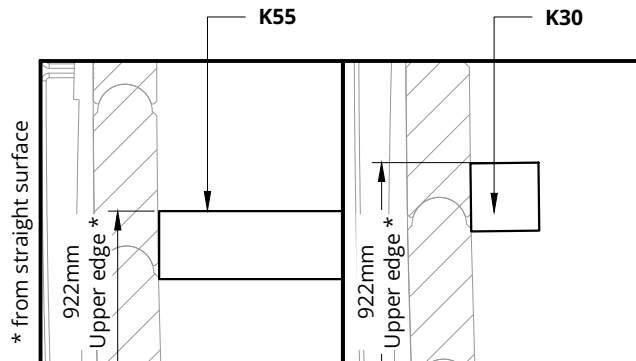

**Notice!** Drill 4mm hole in the K.. square woods before screwing.



S5	Screws 4,5x60 for Spruce Screws 4,2x55 for Thermo	6
S7	Screws 4,5x80 for Spruce Screws 4,2x75 for Thermo	6
		

NB! use a level

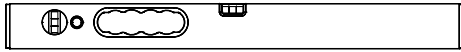

**Please countersink the screw head(s)!**  
**The square wood K90 and cover board D5 are longer, they must be cut to the correct size!**  
**Install the bench I3!**  
**Install some aids to keep the bench level!**  
**Install square woods K10 for bench!**  
**Use glue between the square wood and the wall (only K10 square wood)!**  
**Install the bench leg K90 and the leg cover board D5!**

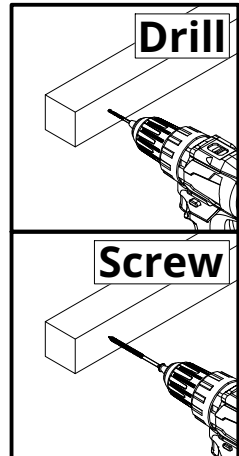

**Notice!**  
 Drill 4mm hole in the K.. square woods before screwing.

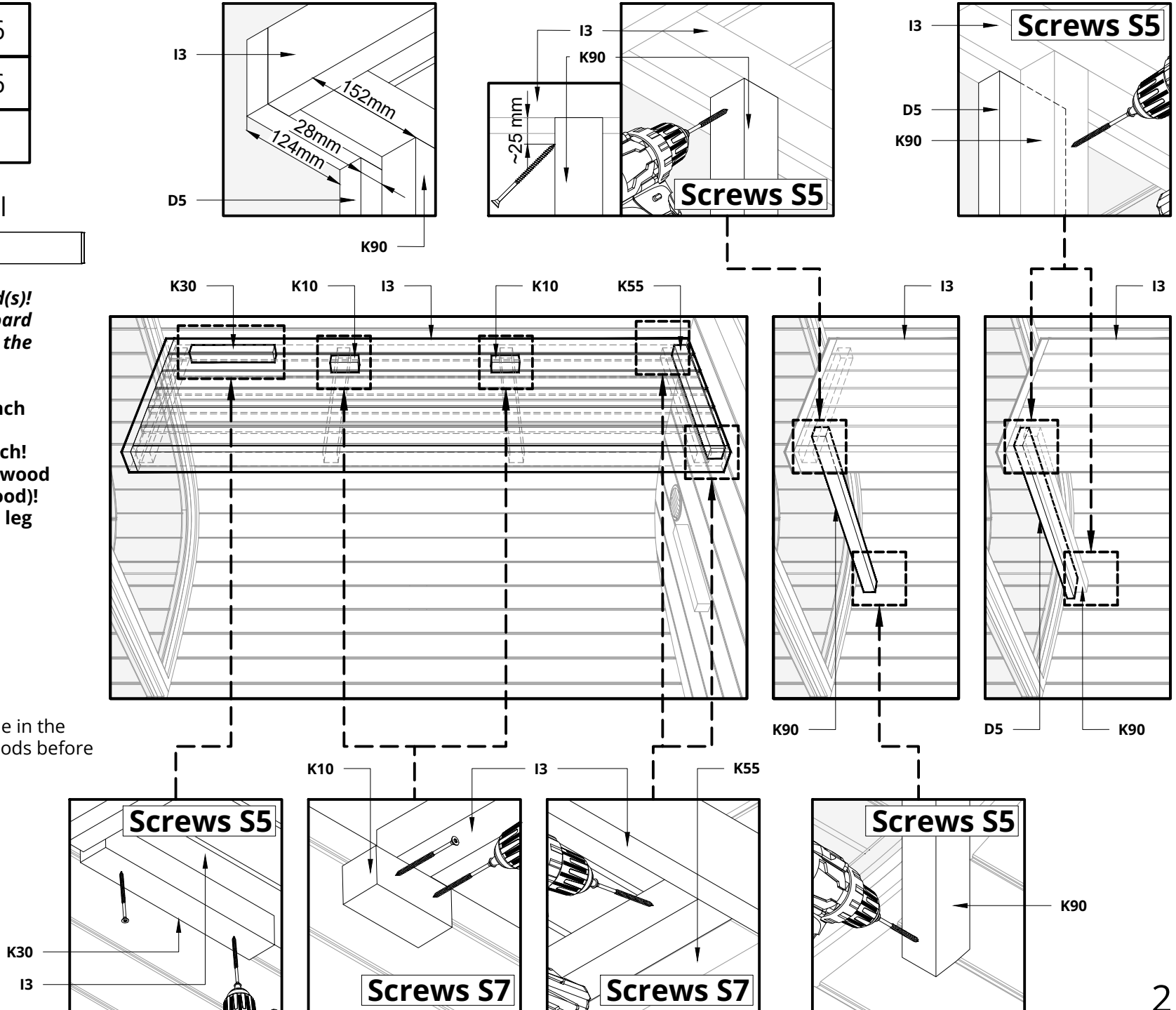

S5	Screws 4,5x60 for Spruce Screws 4,2x55 for Thermo	4
S7	Screws 4,5x80 for Spruce Screws 4,2x75 for Thermo	3
		

NB! use a level

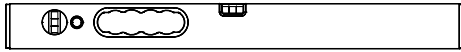

**Please countersink the screw head(s)!**  
**Height measurements are measured from a straight surface!**  
**The square wood K45 and cover board D6 are longer, they must be cut to the correct size!**  
**Install the bench leg cover board!**  
**Install the bench I3!**  
**Install some aids to keep the bench level!**  
**Install the bench leg K45!**

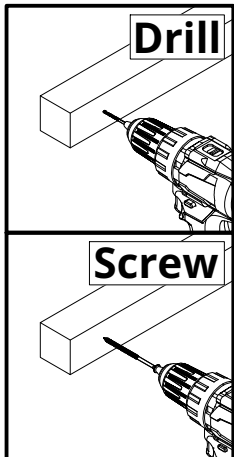
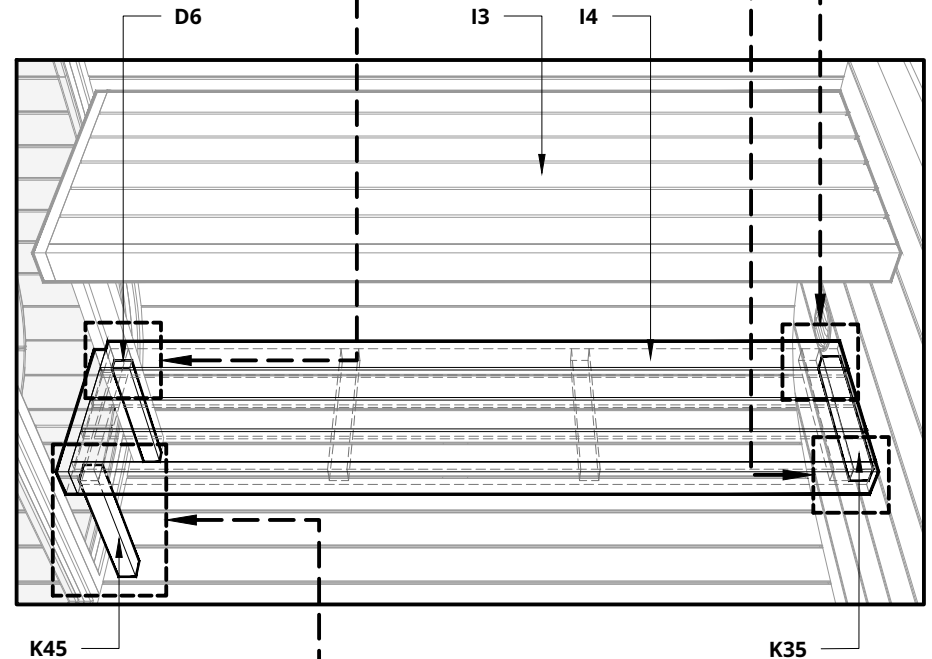
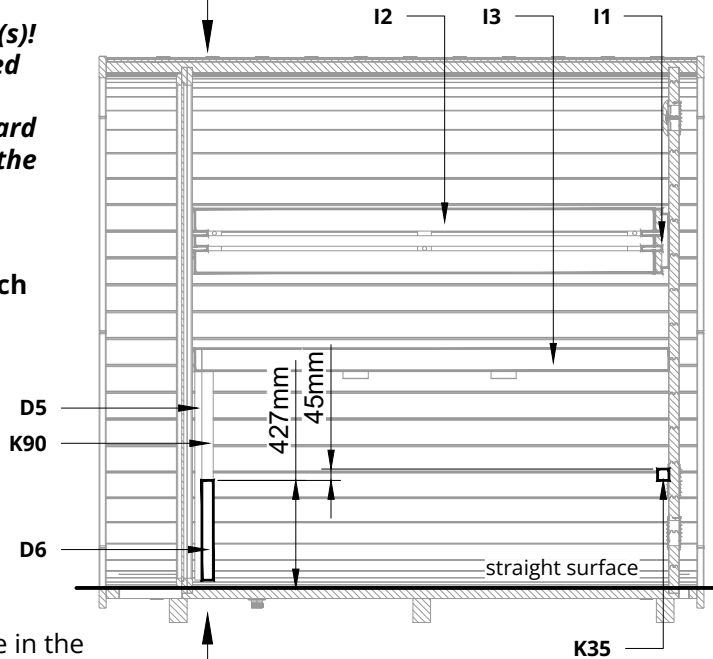
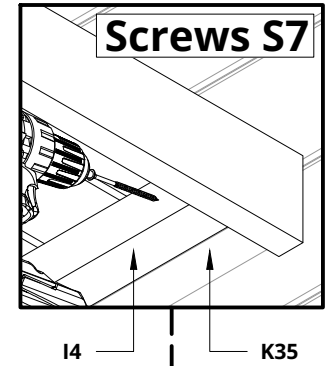
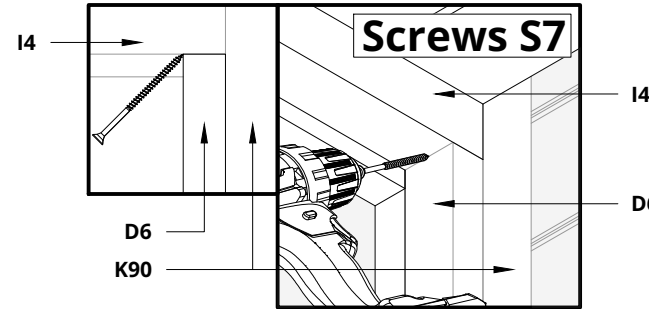
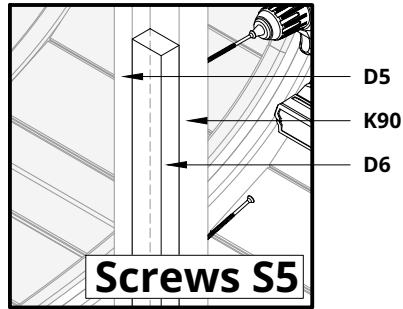

**Notice!**  
 Drill 4mm hole in the K.. square woods before screwing.

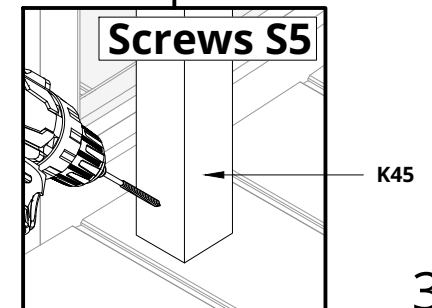
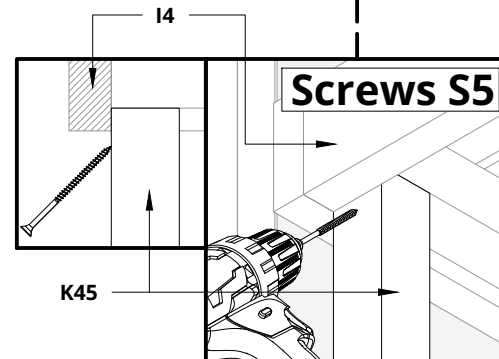
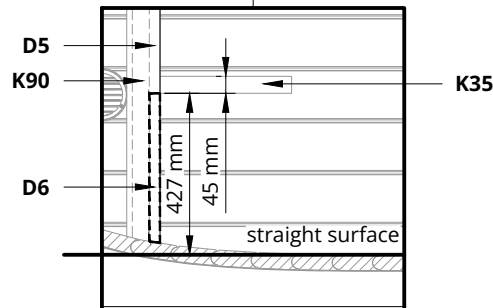

S5	Screws 4,5x60 for Spruce Screws 4,2x55 for Thermo	12
		

NB! use a level

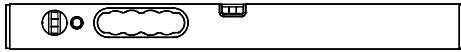

**Please countersink the screw head(s)!**  
**The square wood K45 and cover boards D6 and D7 are longer, they must be cut to the correct size!**  
**Install the bench leg(s) K45 and the leg(s) cover board(s) D6 and D7!**

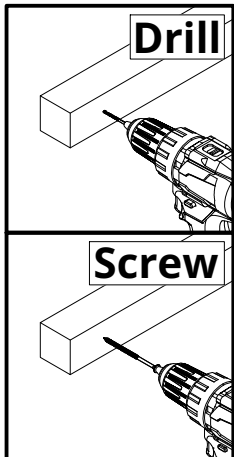

**Notice!**  
 Drill 4mm hole in the K.. square woods before screwing.

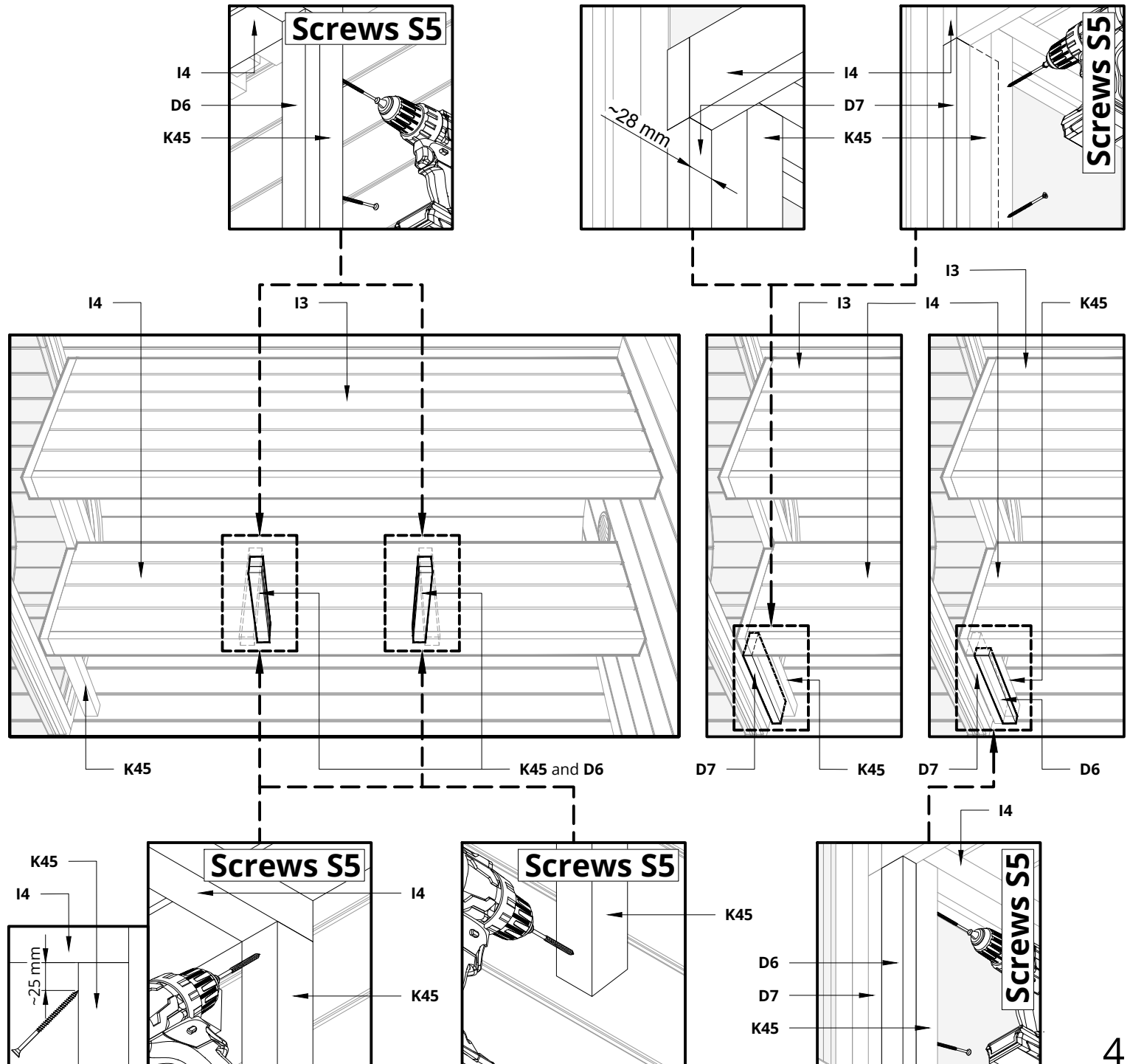

S5	Screws 4,5x60 for Spruce Screws 4,2x55 for Thermo	4
S7	Screws 4,5x80 for Spruce Screws 4,2x75 for Thermo	2



NB! use a level

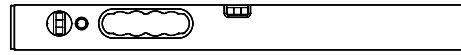

**Please countersink the screw head(s)!**  
**First measure and mark the distance for K34!**  
**Install square woods for bench skirt I5!**  
**Install benches skirt I5!**

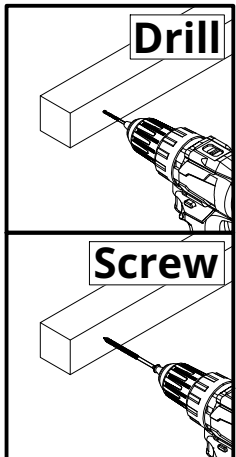
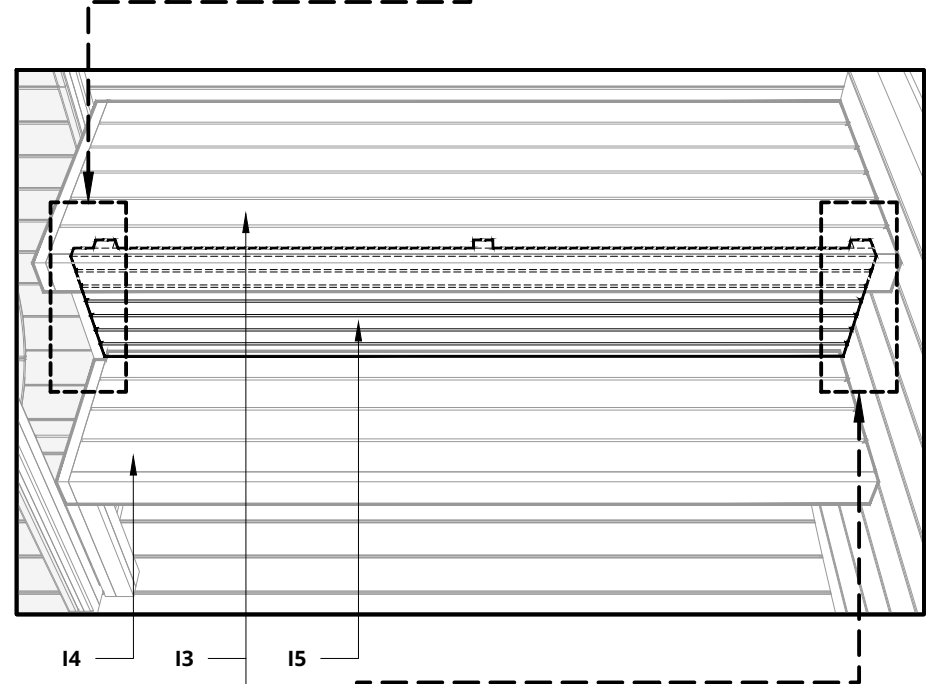
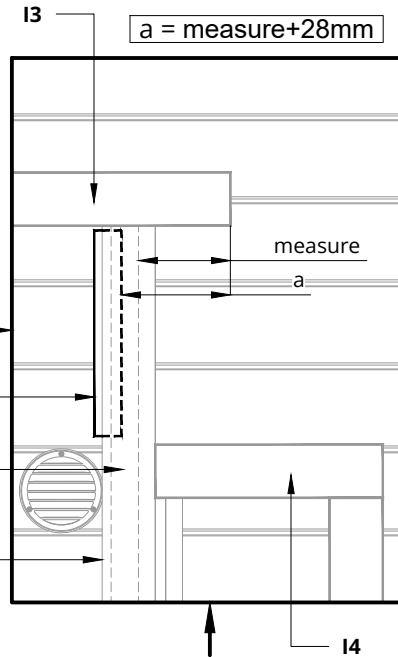
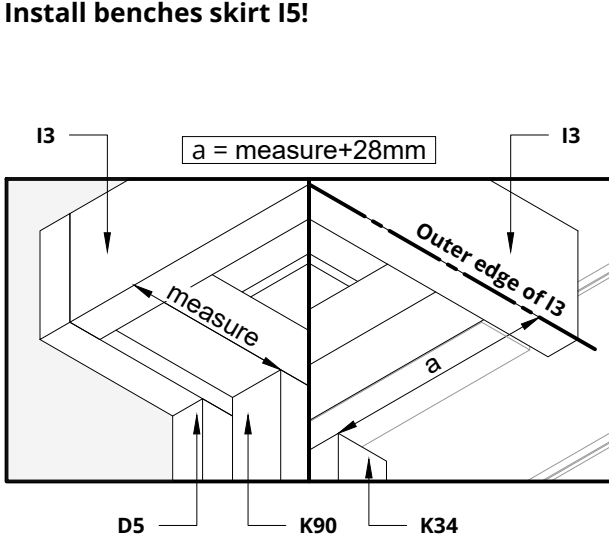
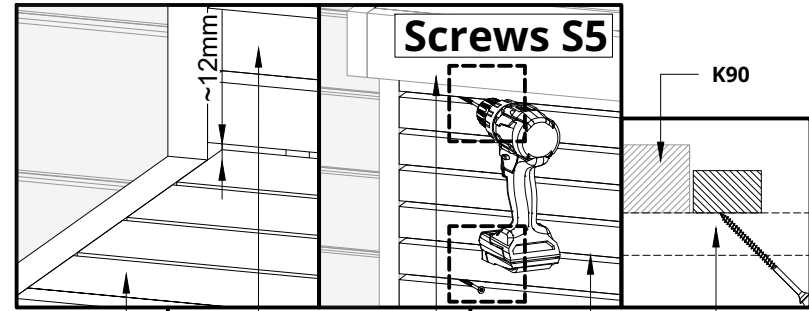

**Notice!**  
 Drill 4mm hole in the K.. square woods before screwing.

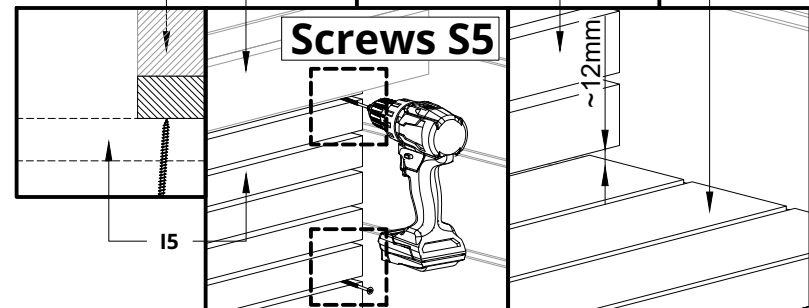
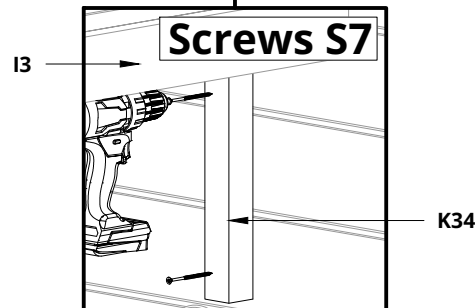

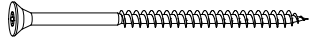
S5	Screws 4,5x60 for Spruce Screws 4,2x55 for Thermo	6
S7	Screws 4,5x80 for Spruce Screws 4,2x75 for Thermo	6
		

NB! use a level



**Please countersink the screw head(s)!**  
**Height measurements are measured from a straight surface!**  
**Install square woods for benches!**  
**Use glue between the square wood and the wall!**

Round Cube (DOUBLE)		
Length	2.4	2.6
<b>a</b>	~360 mm	~456 mm
<b>b</b>	~668 mm	~764 mm
<b>K...</b>	<b>K45</b>	<b>K55</b>

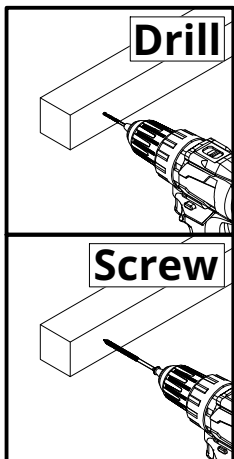

**Notice!**  
 Drill 4mm hole in the K.. square woods before screwing.

For square wood K... See the table

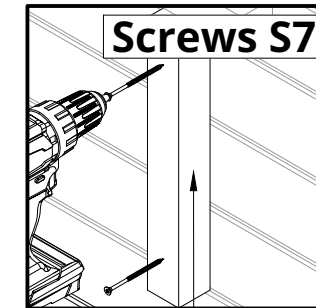
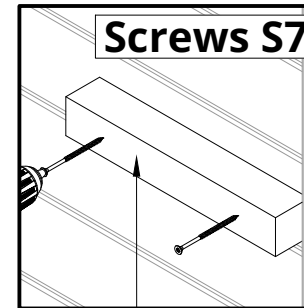
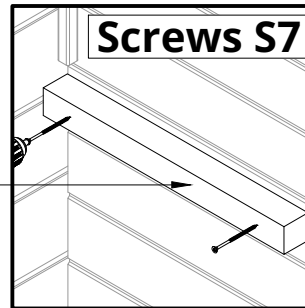

K28

K34

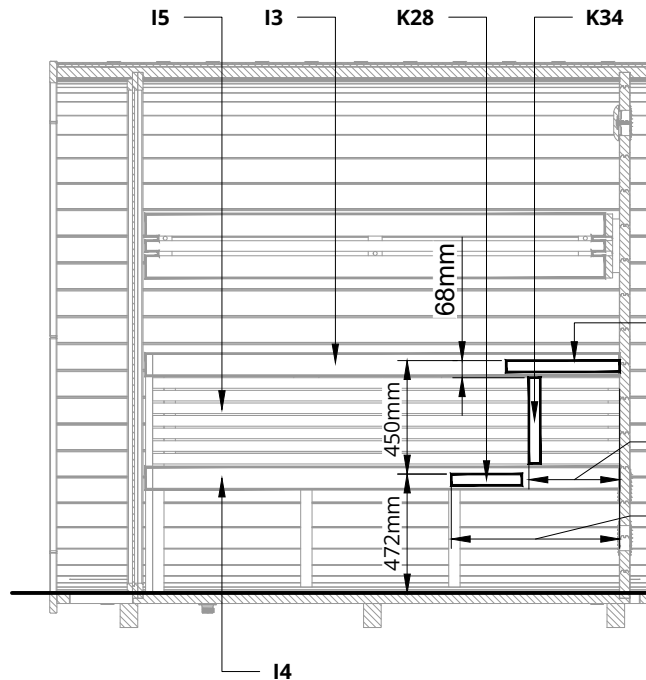

For square wood K... See the table

**Length a**  
See the table

**Length b**  
See the table

straight surface

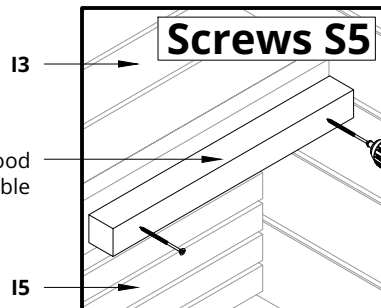
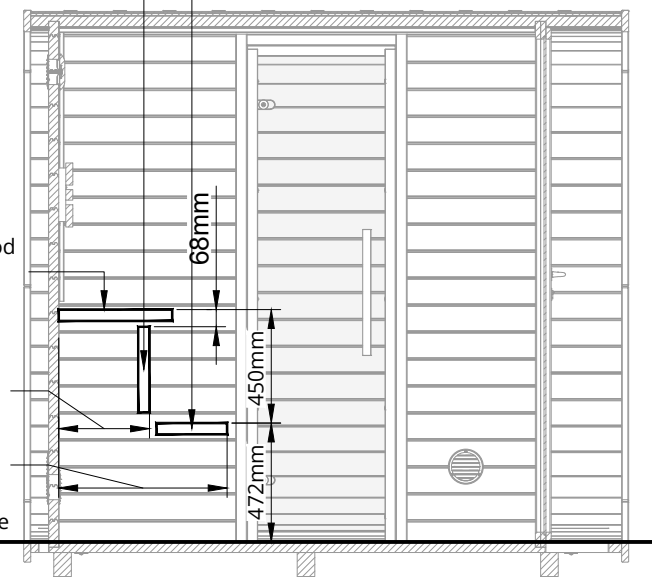

For square wood K... See the table

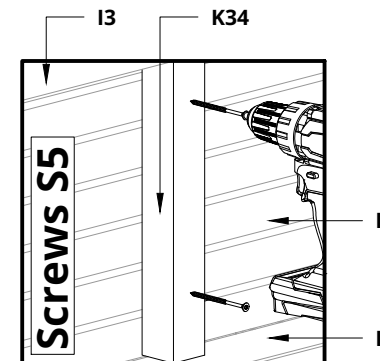
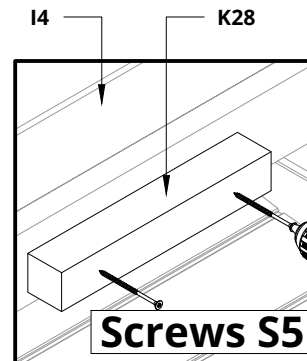

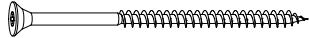

S5	Screws 4,5x60 for Spruce Screws 4,2x55 for Thermo	4
S7	Screws 4,5x80 for Spruce Screws 4,2x75 for Thermo	10
		

**Please countersink the screw head(s)!**  
**Install the benches I6 and I7!**  
**Install square wood K10 for I6 bench!**  
**Use glue between the square wood and the wall (only K10 square wood)!**  
**Install benches skirt I8!**

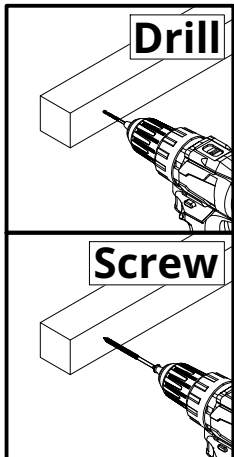
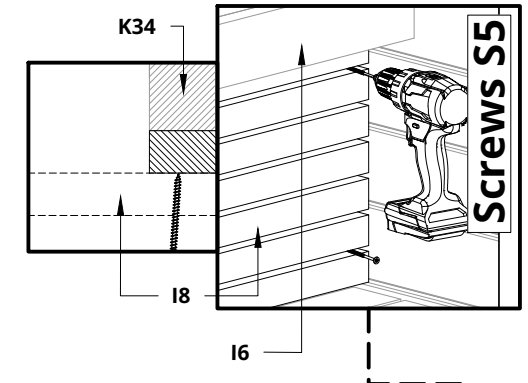
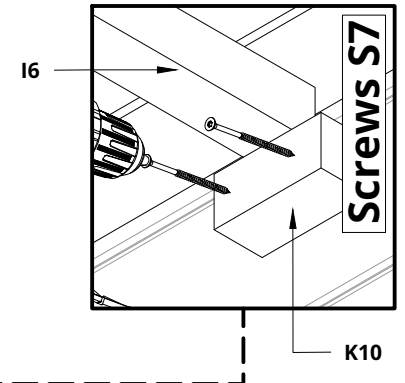
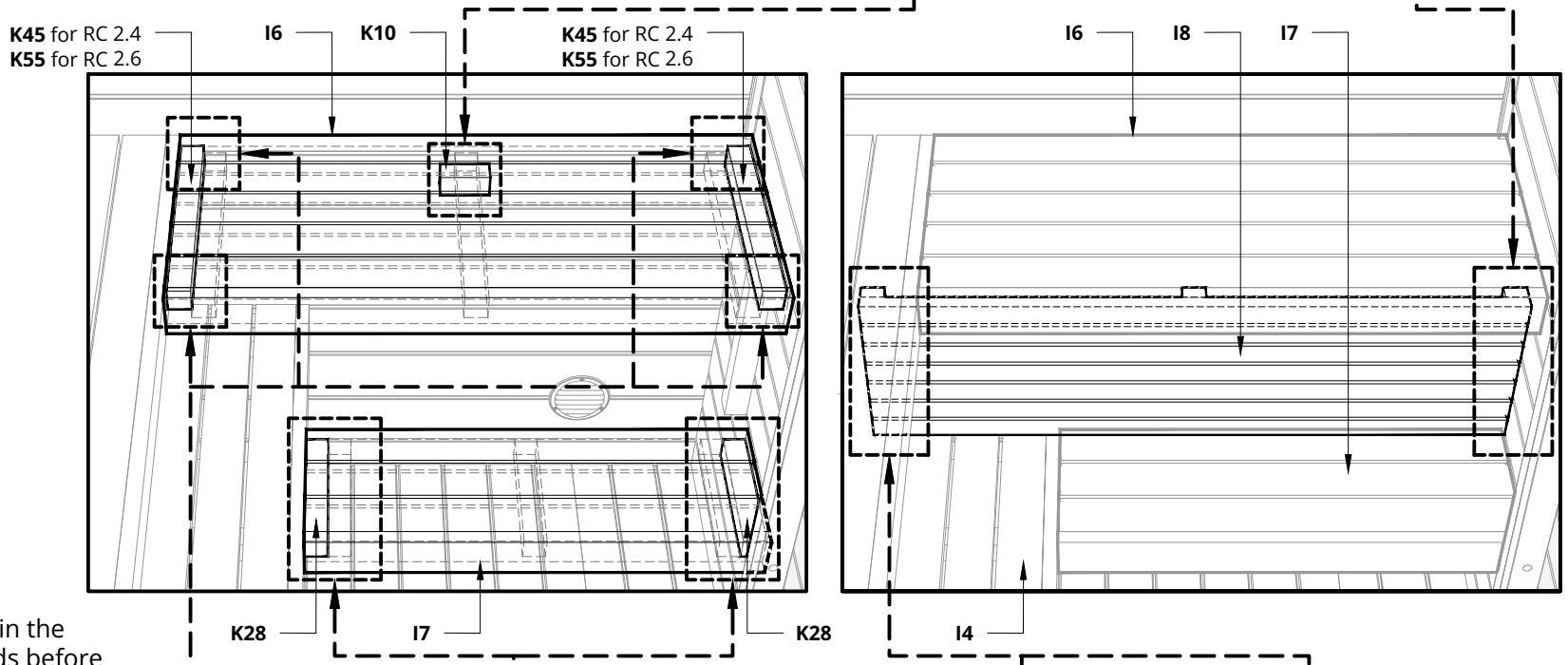
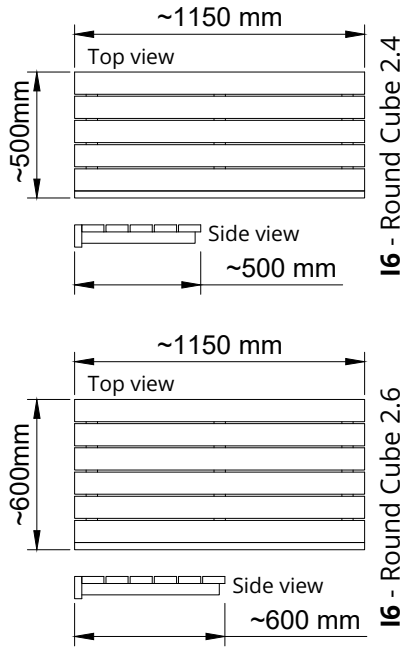

**Notice!**  
 Drill 4mm hole in the K.. square woods before screwing.

K45 for RC 2.4  
 K55 for RC 2.6

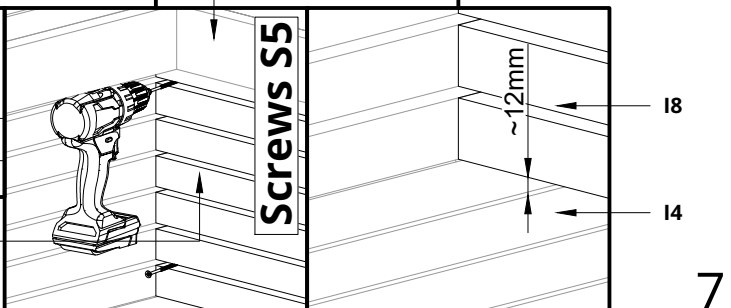
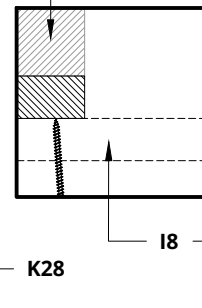
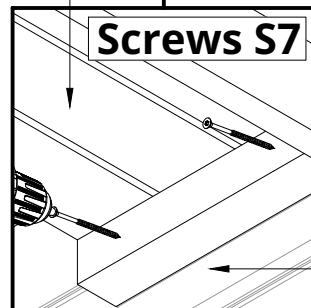
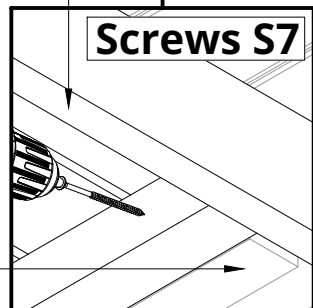

S5	Screws 4,5x60 for Spruce Screws 4,2x55 for Thermo	3
		

Please countersink the screw head(s)!  
Install the step bench 19!  
Place the floor mat F1!

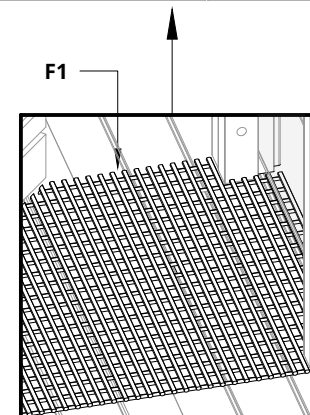
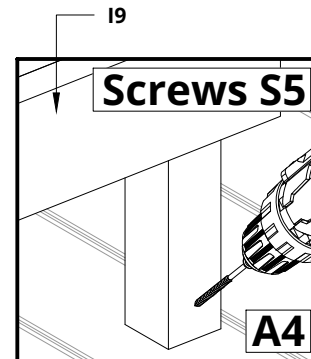
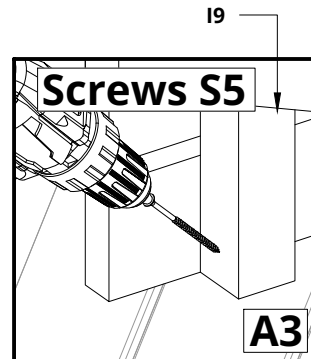
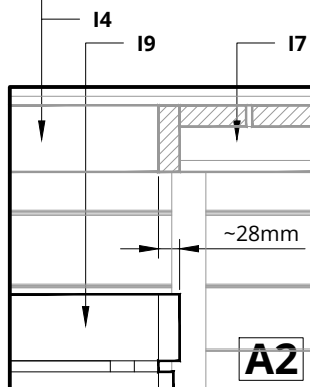
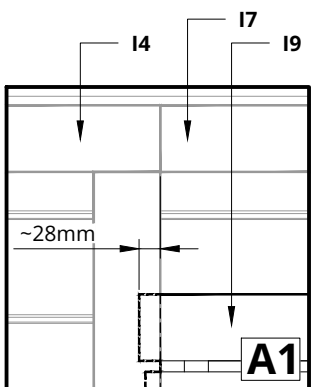
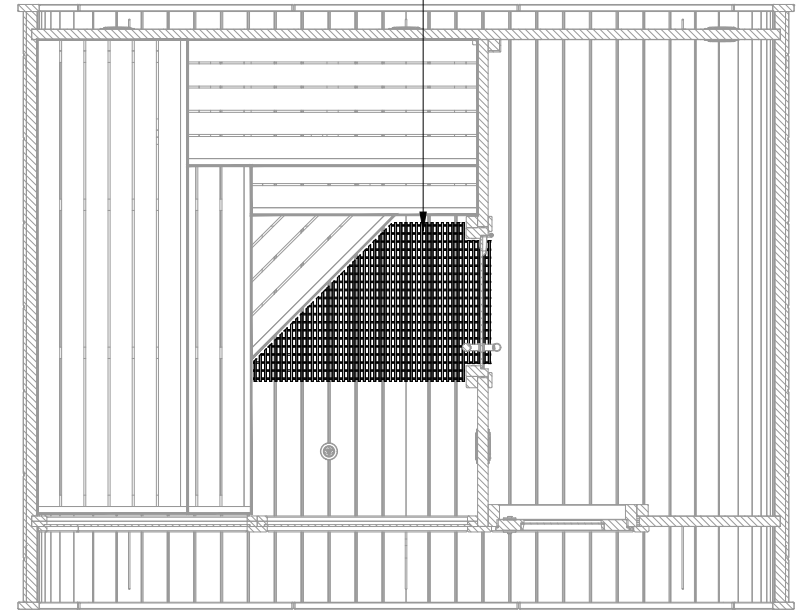
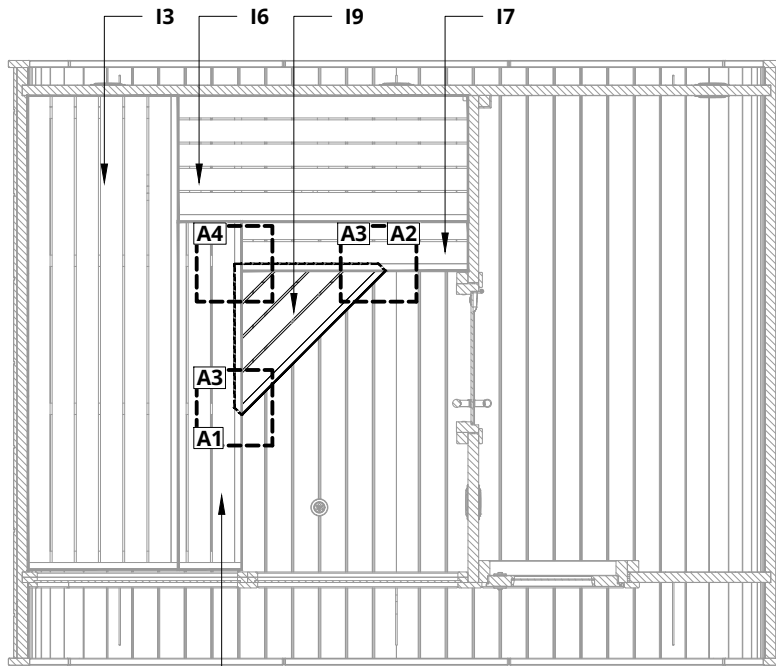
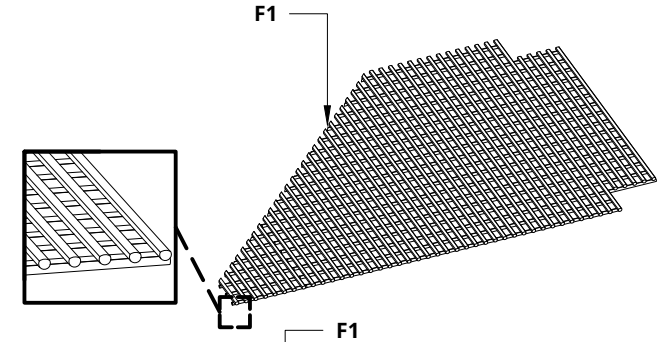
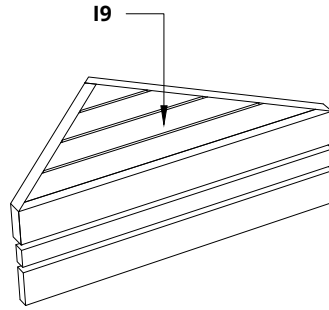

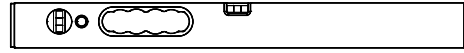

S7	Screws 4,5x80 for Spruce Screws 4,2x75 for Thermo	16
		

NB! use a level

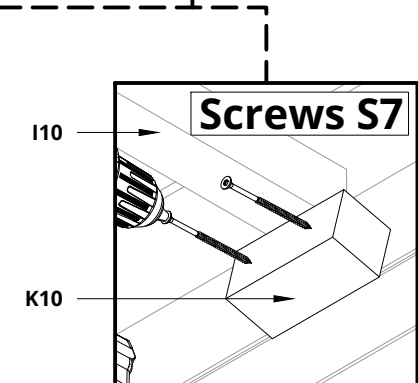
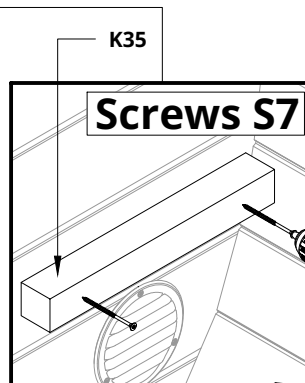
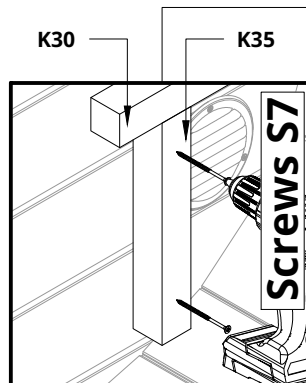
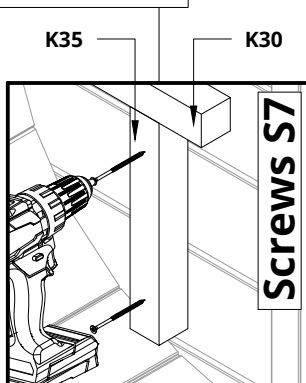
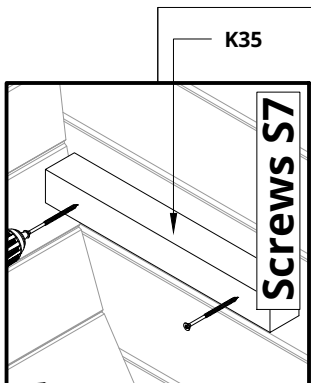
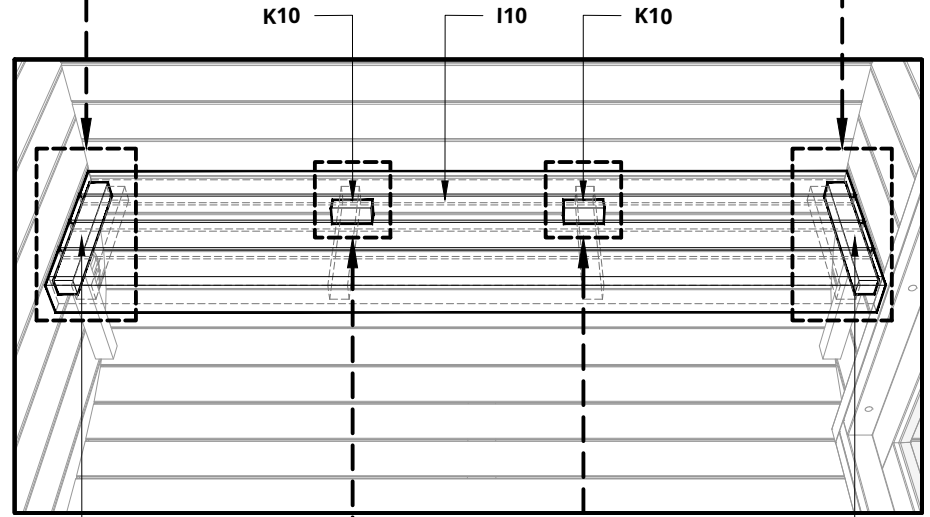
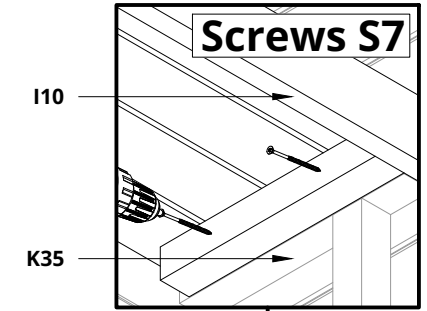
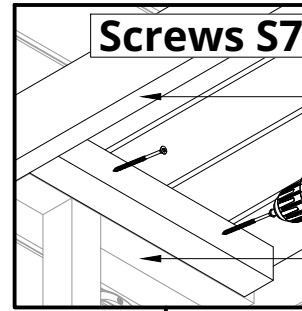
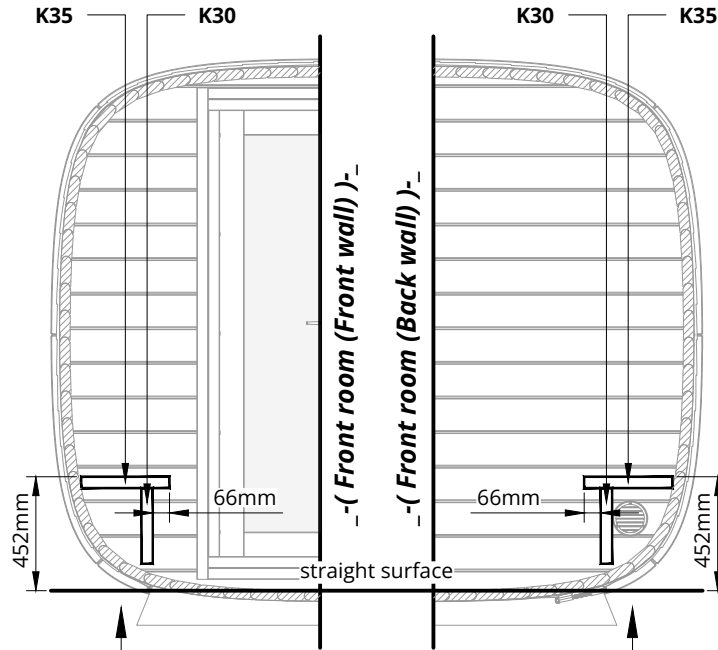
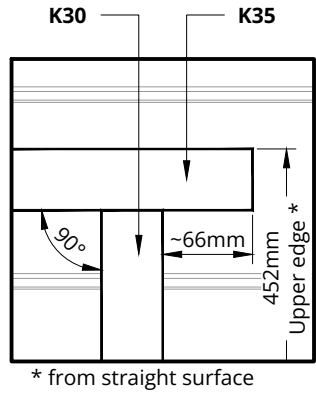

**Please countersink the screw head(s)!**  
**Height measurements are measured from a straight surface!**  
**Install square woods for the bench!**  
**Use glue between the square wood and the wall!**  
**Install the bench I10!**



S5	Screws 4,5x60 for Spruce Screws 4,2x55 for Thermo	4
		

**Please countersink the screw head(s)!**  
**Install bench skirt I11!**  
**Place the floor mat F2!**

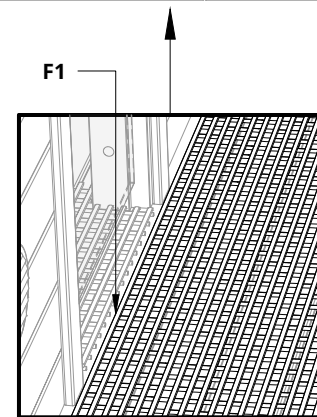
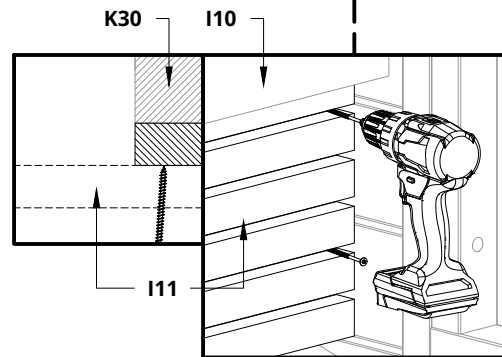
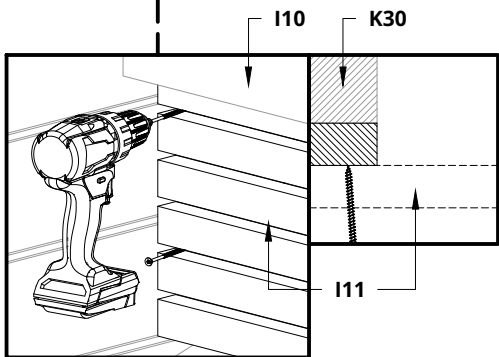
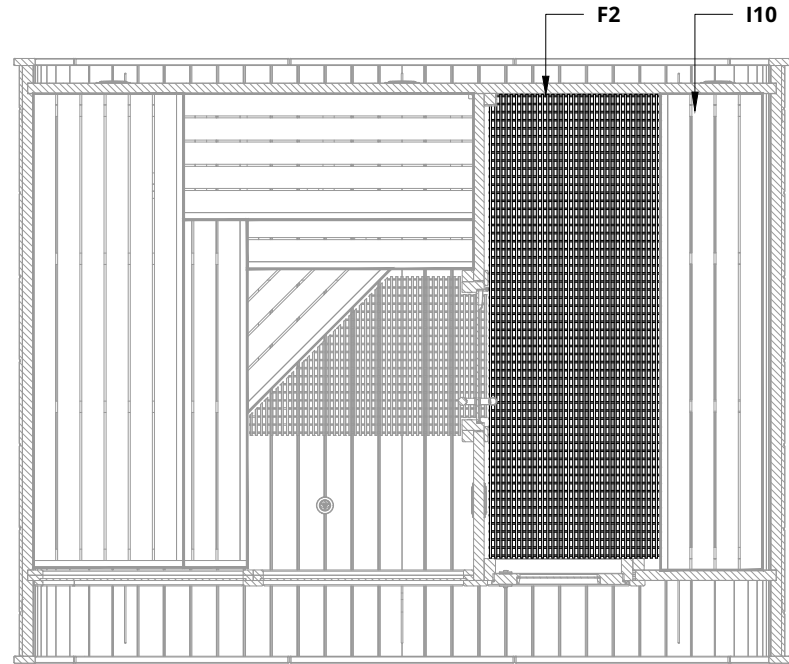
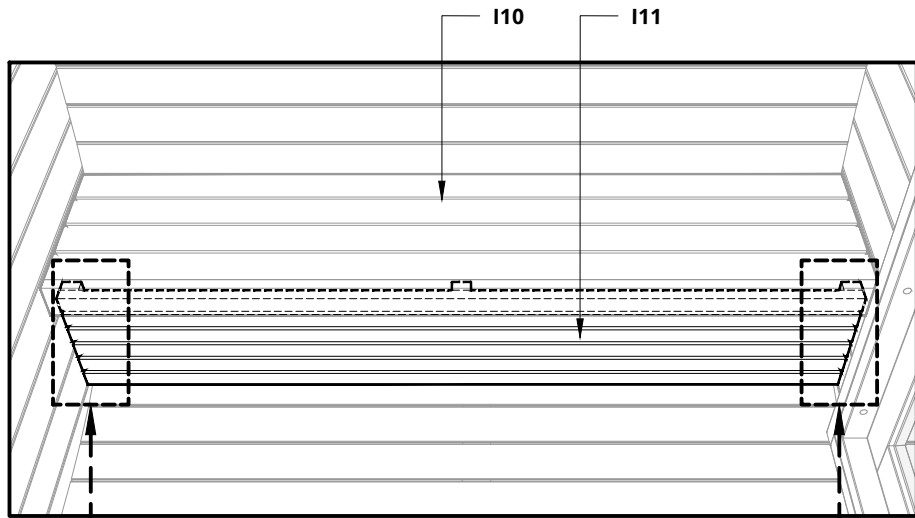
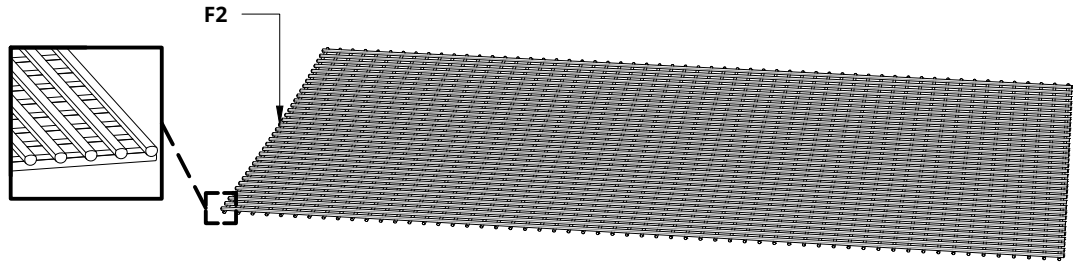

# DOOR ADJUSTMENT MANUAL

## 1) Vertical adjustment of the door sash

The hinge on the side of the sash has a height adjustment bolt (fig.1), from which is possible to adjust the distance between the hinges. Turning clockwise, the hinges move further apart, and the door sash moves higher. It must be remembered that all hinges should be equally set at the same height, so as not to burden just one hinge.



**Fig.1** Sash hinge height adjustment bolt

## 2) Horizontal adjustment of the door sash

The horizontal adjustment of the door sash can be done through the hinge on the frame (fig.2). Turning the bolt clockwise moves the sash closer to the hinge, turning counter-clockwise, moves the sash away from the hinge. The door sash should be adjusted so that the frame is at an equal distance from the edge of the frame. When turning the bolt, you should manually support the sash in the same direction so as not to bend the hinge.



**Fig.2** Frame horizontal direction adjustment bolt

### 3) Adjusting the depth of the door frame

The distance of the door sash to the door frame can be adjusted both by the hinges (fig.3) and by the lock (fig.4). The distance between the sash and the frame can be adjusted by the hinges by turning the bolt in Fig.3 – clockwise, the sash moves closer to the frame, counter-clockwise further. The distance between the door sash and the frame on the lock side can be adjusted by bending the metal “ears” in figure 4 apart with a screwdriver. If necessary, the “ears” can also be bent back with a screwdriver.



**Fig.3** Door sash depth adjustment bolt

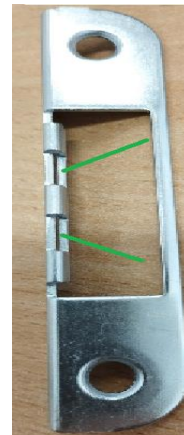

**Fig. 4** Depth adjustment points on the lock side

### 4) Door finishing guide

- Clean the door from dust and dirt
- Remove or cover the lock, handles and hinges
- The product to be finished, must be dry and dust-free
- Finish the door with a suitable primer (NB! Finish both sides of the door)
- Finish the door with a substance suitable for outdoor conditions

**Finishing is important so that the door maintains smooth closing and is durable in outdoor conditions.**

## ADJUSTING THE HINGES

- Remove plastic from hinges (first picture). To remove plastic, lift it from the places indicated by the red lines;
- To regulate hinges you need TORX 30 bit and cordless drill;
- Loosen the bolt shown in figure slightly. (DO NOT OPEN COMPLETELY);
- If both hinge bolts are slightly loosened, it is possible to move the glass in the directions shown in the figure;
- If the glass is set to the required distance, the bolts must be tightened again.



## ADJUSTMENT OF THE ROLLER-LOCK

- PH2 screwdriver required;
- The roller lock can be adjusted by turning the screw indicated by the red line;
- Turning clockwise moves the roller inward and turning counter-clockwise moves the roller outward;
- The roller should be adjusted so that the glass moves freely behind the roller without applying force.

